

Altivar 32

Variable speed drives for
synchronous and asynchronous motors

Modbus Communication Manual

03/2010



The information provided in this documentation contains general descriptions and/or technical characteristics of the performance of the products contained herein. This documentation is not intended as a substitute for and is not to be used for determining suitability or reliability of these products for specific user applications. It is the duty of any such user or integrator to perform the appropriate and complete risk analysis, evaluation and testing of the products with respect to the relevant specific application or use thereof. Neither Schneider Electric nor any of its affiliates or subsidiaries shall be responsible or liable for misuse of the information contained herein. If you have any suggestions for improvements or amendments or have found errors in this publication, please notify us.

No part of this document may be reproduced in any form or by any means, electronic or mechanical, including photocopying, without express written permission of Schneider Electric.

All pertinent state, regional, and local safety regulations must be observed when installing and using this product. For reasons of safety and to help ensure compliance with documented system data, only the manufacturer should perform repairs to components.

When devices are used for applications with technical safety requirements, the relevant instructions must be followed.

Failure to use Schneider Electric software or approved software with our hardware products may result in injury, harm, or improper operating results.

Failure to observe this information can result in injury or equipment damage.

© 2010 Schneider Electric. All rights reserved.

Table of Contents

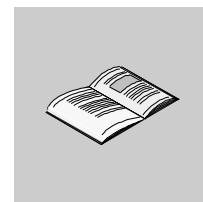

	Safety Information	5
	About the Book	6
Chapter 1	Hardware Setup	8
	Connection to ATV32	9
	Protection Against Interference	9
	RS485 Bus Schematic	10
Chapter 2	Configuration	11
	Notation	12
	Configuring the Communication Parameters	13
	Configuring the Control Channels	14
	I/O Scanner	16
	Configuring Monitor Parameters	18
	Configuring Communication Interruption Management	19
Chapter 3	Diagnostics	20
	Communication Diagnostics	21
	Modbus Counters	21
	Modbus Communication Stat	21
Chapter 4	Profiles	22
	Definition of a Profile	23
	Functional Profiles Supported by the Altivar 32	24
Chapter 5	CiA[®]402 - IEC61800-7 Functional Profile	25
	Functional Description	26
	CiA402 State Chart	27
	Description of States	28
	Summary	29
	Control Word (CMd)	30
	Stop Commands	31
	Assigning Control Word Bits	31
	Status Word (EtA)	32
	Starting Sequence	33
	Sequence for a Drive Powered by the Power Section Line Supply	34
	Sequence for a Drive With Separate Control Section	36
	Sequence for a Drive with Line Contactor Control	39
Chapter 6	Software Setup with Unity (M340)	41
	Introduction	42
	Drive Configuration	43
	Modbus Master Configuration	44
Chapter 7	Software Setup with SoMachine (M238)	49
	Introduction	50
	Drive Configuration	51
	Modbus Master Configuration	52
Chapter 8	Modbus Functions	56
	Modbus Protocol	57

Supported Modbus Functions. 58

Safety Information

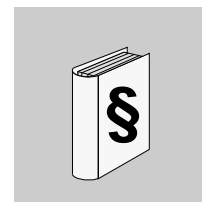

Important Information

NOTICE

Read these instructions carefully, and look at the equipment to become familiar with the device before trying to install, operate, or maintain it. The following special messages may appear throughout this documentation or on the equipment to warn of potential hazards or to call attention to information that clarifies or simplifies a procedure.



The addition of this symbol to a Danger or Warning safety label indicates that an electrical hazard exists, which will result in personal injury if the instructions are not followed.



This is the safety alert symbol. It is used to alert you to potential personal injury hazards. Obey all safety message that follow this symbol to avoid possible injury or death.

▲ DANGER

DANGER indicates an imminently hazardous situation, which, if not avoided, **will result** in death or serious injury.

▲ WARNING

WARNING indicates a potentially hazardous situation, which, if not avoided, **can result** in death, serious injury or equipment damage.

▲ CAUTION

CAUTION indicates a potentially hazardous situation, which, if not avoided, **can result** in injury or equipment damage.

CAUTION

CAUTION, used without the safety alert symbol, indicates a potentially hazardous situation which, if not avoided, **can result** in equipment damage.

PLEASE NOTE

The word “drive” as used in this manual refers to the controller portion of the adjustable speed drive as defined by NEC.

Electrical equipment should be installed, operated, serviced, and maintained only by qualified personnel. No responsibility is assumed by Schneider Electric for any consequences arising out of the use of this material.

About the Book

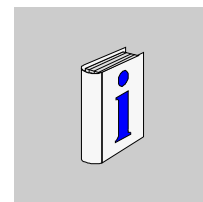

At a Glance

Document Scope

The purpose of this document is to:

- show you how to install the Modbus fieldbus on your Altivar 32,
- show you how to configure the Altivar 32 to use Modbus for monitoring and control,
- provide examples of setup using SoMachine and Unity.

NOTE: Read and understand this document and all related documents (see below) before installing, operating, or maintaining your ATV32.

Validity Note

This documentation is valid for the Altivar 32 Modbus fieldbus.

Related Documents

Title of Documentation	Reference Number
ATV32 Quick Start	S1A41715
ATV32 Installation manual	S1A28686
ATV32 Programming manual	S1A28692
ATV32 CANopen® manual	S1A28699
ATV32 Communication Parameters	S1A44568
ATV32 Atex manual	S1A45605
ATV32 Safety manual	S1A45606
ATV32 other option manuals: see www.schneider-electric.com	

You can download the latest versions of these technical publications and other technical information from our website at www.schneider-electric.com.

Product Related Information

⚠ DANGER

UNINTENDED EQUIPMENT OPERATION

- Read and understand this manual before installing or operating the Altivar 32 drive.
- Any changes made to the parameter settings must be performed by qualified personnel.

Failure to follow these instructions will result in death or serious injury.

⚠ ⚠ DANGER

HAZARD OF ELECTRIC SHOCK, EXPLOSION OR ARC FLASH

- Read and understand this manual before installing or operating the Altivar 32 drive. Installation, adjustment, repair, and maintenance must be performed by qualified personnel.
- The user is responsible for compliance with all international and national electrical code requirements with respect to grounding of all equipment.
- Many parts of this drive, including the printed circuit boards, operate at the line voltage. **DO NOT TOUCH.** Use only electrically insulated tools.
- **DO NOT** touch unshielded components or terminal strip screw connections with voltage present.
- **DO NOT** short across terminals PA/+ and PC/- or across the DC bus capacitors.
- Before servicing the drive:
 - Disconnect all power, including external control power that may be present.
 - Place a “DO NOT TURN ON” label on all power disconnects.
 - Lock all power disconnects in the open position.
 - **WAIT 15 MINUTES** to allow the DC bus capacitors to discharge.
 - Measure the voltage of the DC bus between the PA/+ and PC/- terminals to ensure that the voltage is less than 42 Vdc.
 - If the DC bus capacitors do not discharge completely, contact your local Schneider Electric representative. Do not repair or operate the drive
- Install and close all covers before applying power or starting and stopping the drive.

Failure to follow these instructions will result in death or serious injury.

⚠ WARNING

DAMAGE DRIVE EQUIPMENT

Do not operate or install any drive or drive accessory that appears damaged.

Failure to follow these instructions can result in death, serious injury, or equipment damage.

⚠ WARNING

LOSS OF CONTROL

- The designer of any control scheme must
 - consider the potential failure modes of control paths and,
 - for certain critical control functions, provide a means to achieve a safe state during and after a path failure.

Examples of critical control functions are emergency stop and overtravel stop.

- Separate or redundant control paths must be provided for critical control functions.
- System control paths may include communication links. Consideration must be given to the implications of unanticipated transmission delays or failures of the link.⁽¹⁾

Failure to follow these instructions can result in death, serious injury, or equipment damage.

(1) For additional information, refer to NEMA ICS 1.1 (latest edition), “Safety Guidelines for the Application, Installation, and Maintenance of Solid State Control” and to NEMA ICS 7.1 (latest edition), “Safety Standards for Construction and Guide for Selection, Installation and Operation of Adjustable-Speed Drive Systems.”

Hardware Setup



1

What's in this Chapter?

This chapter contains the following topics:

Topic	Page
Connection to ATV32	9
Protection Against Interference	9
RS485 Bus Schematic	10

Connection to ATV32

Connection accessories should be ordered separately (please consult our catalogues).

Connect the RJ45 cable connector to the ATV32 connector.

The following table describes the pin out of the ATV32 RJ45 connector:

Pin	Signal
1	Reserved for CANopen ⁽³⁾
2	
3	
4	D1 ⁽¹⁾
5	D0 ⁽¹⁾
6	-
7	VP, 10 Vdc ⁽²⁾
8	Common

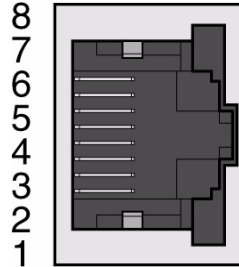

(1) Modbus signals

(2) Supply for RS232 / RS485 converter or a remote terminal

(3) The RJ45 base port is also used for the connection to a CANopen network when any CANopen option modules are plugged

Protection Against Interference

- Use the Schneider Electric cable with 2 pairs of shielded twisted conductors (reference: TSXCSA100, TSXCSA200, TSXCSA500).
- Keep the Modbus cable separated from the power cables (30 cm (11.8 in.) minimum).
- Make any crossovers of the Modbus cable and the power cables at right-angles, if necessary.

For more information, please refer to the TSX DG KBL E manual: "Electromagnetic compatibility of industrial networks and fieldbuses".

RS485 Bus Schematic

The RS485 standard allows variants of different characteristics:

- polarisation
- line terminator
- distribution of a reference potential
- number of slaves
- length of bus

The new Modbus specification published on the Modbus.org site in 2006 contains precise details of all these characteristics. They are also summarised in Standard schematic section. The new Schneider Electric devices conform to this specification.

Schematic Diagram

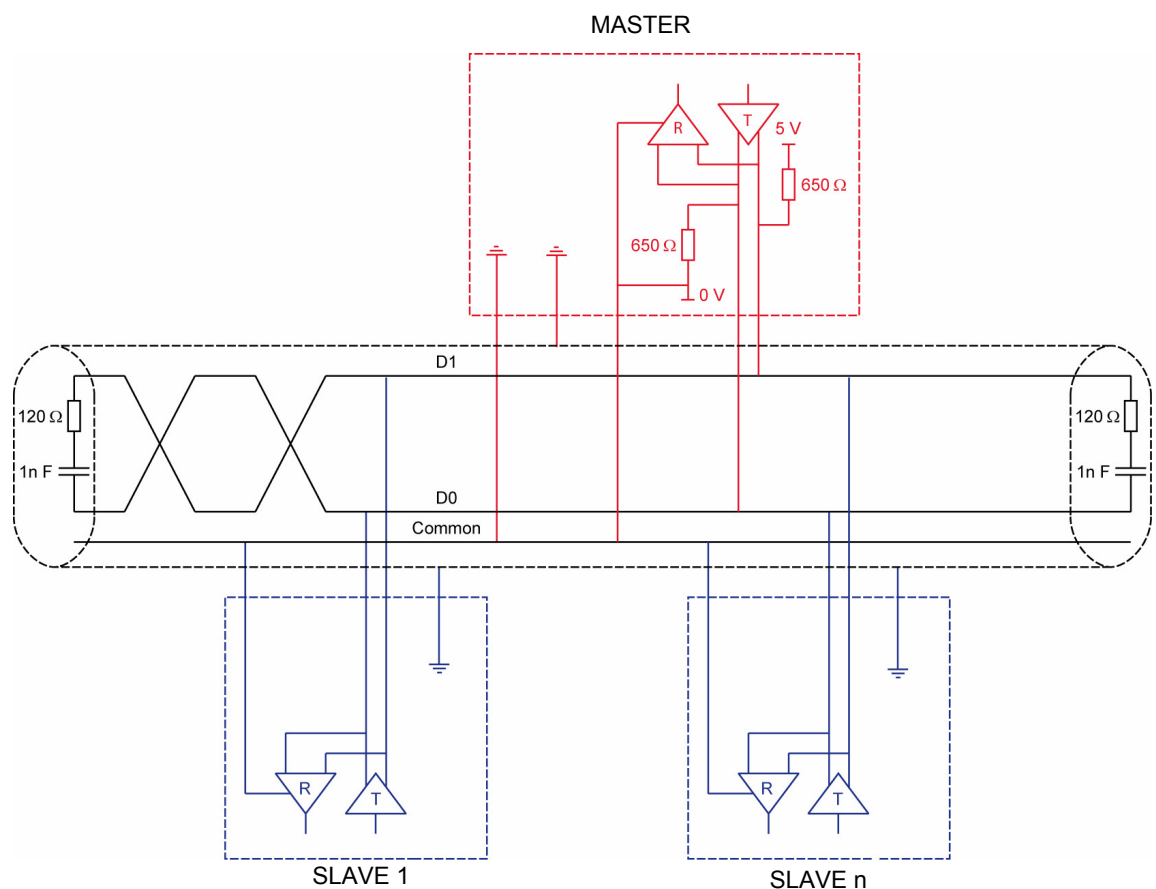

Characteristic	Definition
Type of trunk cable	Shielded cable with 1 twisted pair and at least a 3 rd conductor
Maximum length of bus	1000m at 19200 bps with the Schneider Electric TSX CSA*** cable
Maximum number of stations (without repeat)	32 stations, i.e. 31 slaves
Maximum length of tap links	- 20m for one tape link - 40m divided by the number of tape links on a multiple junction box
Bus polarisation	- One 450 to 650Ω pull-down resistor at 5V (650Ω recommended) - One 450 to 650Ω pull-down resistor at the Common (650Ω recommended) This polarisation is recommended for the master
Line terminator	One 120 H 0.25W resistor in series with 1nF 10V capacitor
Common polarity	Yes (Common), connected to the protective ground at one or more point of the bus

Configuration



2

What's in this Chapter?

This chapter contains the following topics:

Topic	Page
Notation	12
Configuring the Communication Parameters	13
Configuring the Control Channels	14
I/O Scanner	16
Configuring Monitor Parameters	18
Configuring Communication Interruption Management	19

Notation

Drive Terminal Displays

The graphic display terminal (to be ordered separately - reference VW3 A1 101) menus are shown in square brackets.

Example: **[COMMUNICATION]**

The integrated 7-segment display terminal menus are shown in round brackets.

Example: **(L F F -)**

Parameter names are displayed on the graphic display terminal in square brackets.

Example: **[Fallback speed]**

Parameter codes are displayed on the integrated 7-segment display terminal in round brackets.

Example: **(L F F)**

Formats

In this manual, hexadecimal values are written as follows: 16#

Configuring the Communication Parameters

Configuration of the Modbus communication functions of the Altivar 32 can be accessed from the **[CONFIGURATION] (C O N F)** / **[FULL] (F U L L)** / **[COMMUNICATION] (C O N -)** menu / **[MODBUS NETWORK] (M D I -)**.

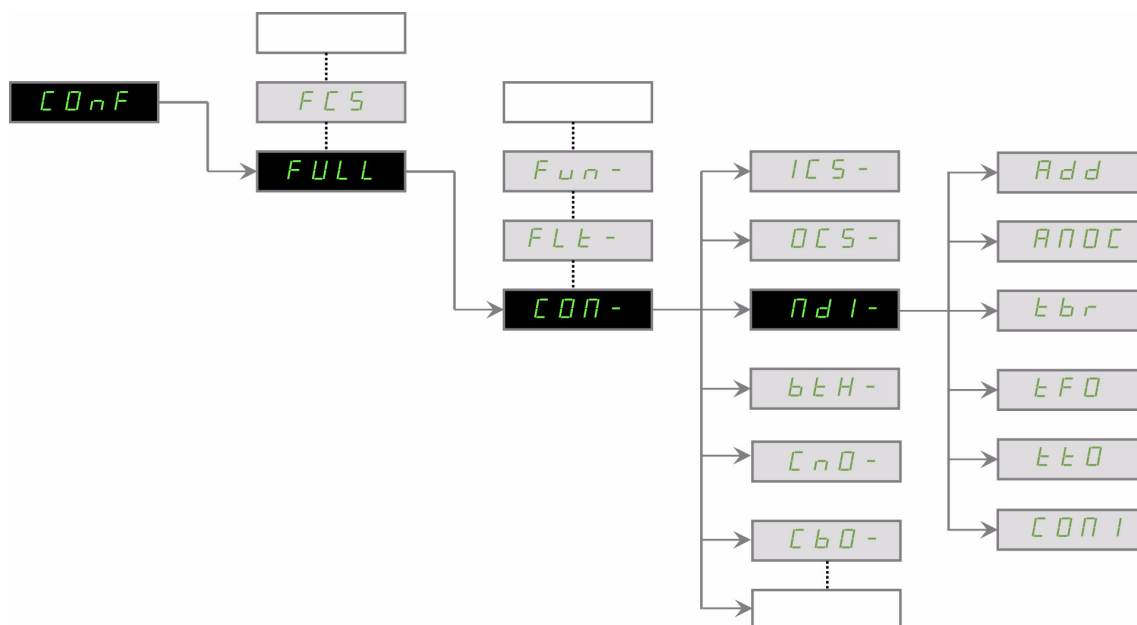

Parameter description	Range or listed values	Default	Possible value	Modbus address
[Modbus Address] (ADD)	1 to 247 0: OFF (broadcast only, see "Modbus Protocol" on page 57)	[OFF] (OFF)	[OFF; 1 to 247] (OFF; 1 . . . 247)	16#1771 = 6001
[Modbus baud rate] (tbr)	4,8 kbps 9,6 kbps 19,6 kbps ⁽¹⁾ 38,4 kbps	[19.2 kbps] (19.2)	[4.8] (4.8) [9.6] (9.6) [19.2] (19.2) [38.4] (38.4)	16#1773 = 6003
[Modbus format] (tFD)	8 data bits, odd parity, 1 stop bit 8 data bits, even parity, 1 stop bit ⁽¹⁾ 8 data bits, no parity, 1 stop bit 8 data bits, no parity, 2 stop bits	[8E1] (8E1)	[8O1] (8O1) [8E1] (8E1) [8N1] (8N1) [8N2] (8N2)	16#1774 = 6004
[Modbus time out] (tEO)	Adjustable from 0.1 to 30s	[10 s] (10)	[0.1 to 30.0] (0.1 . . . 30.0)	16#1775 = 6005

(1) The graphic display terminal will only work with these values. Any other value will make communication with the graphic display terminal impossible.

The drive must be restarted in order to take into account the Modbus parameter.

Configuring the Control Channels

This chapter explains through 3 examples how to configure the drive for operation from communication network:

- I/O Mode - a simple command Word (based on Forward, reverse and reset binary commands).
- Combined Mode (with native profile CiA402) - Both reference and command word come from the communication network.
- Separate (with native profile CiA402) - Reference and command come from separate sources: for example, the command (in CiA402) comes from the communication network and the reference from the HMI.

Configuration of the Drive for Operation in I/O Profile

To illustrate the I/O Profile, we will describe a simple example, which can be of course extended with additional features. The Command word is made of Run forward (bit 0 of CMD), run reverse (bit 1 of CMD), and a detected fault reset (bit 7 of CMD).

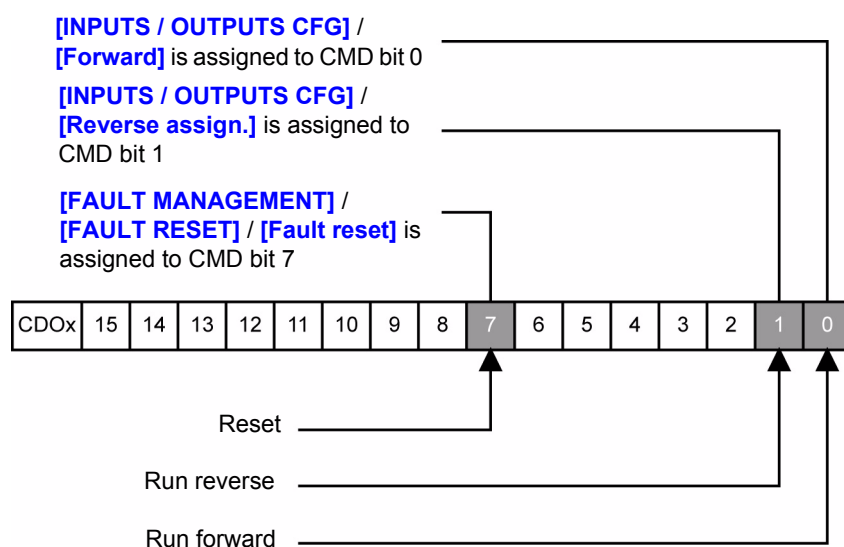

The settings will be the following:

[Ref.1 channel] (F r l)	[Modbus] (M d b)
[Profile] (E H C F)	[I/O profile] (I O)
[Cmd switching] (E C S)	Default
[Cmd channel 1] (E d l)	[Modbus] (M d b)

The bits of the command word must now be configured.

In the **[INPUTS / OUTPUTS CFG]** Menu, configure:

[Forward] (F r d)	[Cd00] (E d 0 0)
[Reverse assign.] (r r S)	[Cd01] (E d 0 1)

In the **[FAULT MANAGEMENT]** menu, **[FAULT RESET]** submenu, configure:

[Fault reset] (r S F)	[Cd07] (E d 0 7)
------------------------------	-------------------------

Configuration of the Drive for Operation With CiA402 Profile in Combined Mode

This chapter describes how to configure the settings of the drive if it is controlled in CiA402 Mode. The example focuses on the Not separate mode (Combined). Additional modes such separate Mode are detailed in the ATV32 Programming manual.

In the Command Menu **[Command]** (C E L -):

- **[Ref.1 channel]** (F r l): is set on according to the communication source you can choice in the following table

Origin of the control	Ref1 Channel setting
Modbus base port	[Modbus] (M d b)

- **[Profile]** (C H C F): defines if the drives operates in combined mode (reference and command from the same channel)

For the current example, CHCF will be adjusted to SIM, as reference and control are originated from the communication network.

Profile	Ref1 Channel setting
CiA402 Combined mode	[Not separ.] (S I N) (factory setting)

Configuration of the Drive for Operation with CiA402 Profile in Separate Mode

Alternate combinations are possible, see the ATV32 programming manual for the list of possible settings.

Example:

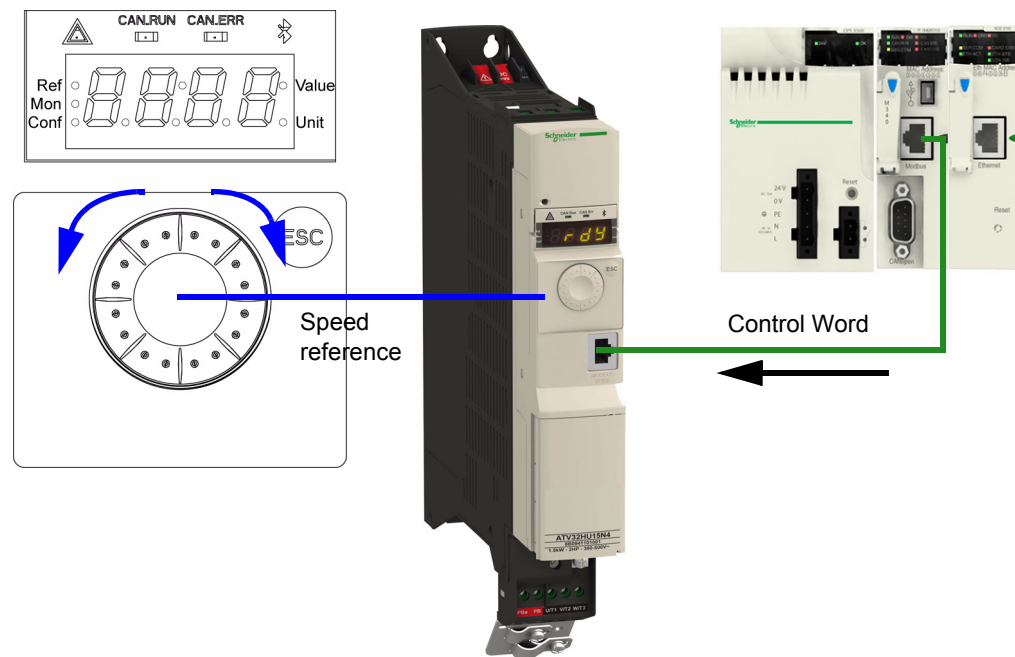

The drive is controlled from the communication (1 of the 3 following settings MDB, CAN or NET) but the reference is adjusted on the HMI. The control word comes from the controller and is written according to CiA402 profile.

The settings will be the following:

[Ref.1 channel] (F r l)	[AI virtual 1] (R I U l)
[Profile] (C H C F)	[Separate] (S E P)
[Cmd switching] (C C S)	Default
[Cmd channel 1] (C d l)	[Modbus] (M d b)

I/O Scanner

Introduction

The communication scanner is useful when used in combination by the Modbus client device with the function "Read/Write Multiple registers": 23 (16#17), which provides in a single telegram a read multiple registers and a write multiple registers. The detail of the function 23 is described in the supported Modbus functions.

Local Configuration of the Communication Scanner

The communication scanner is accessible via the following menus: **[COMMUNICATION]** (C 0 0 -) and **[COM. SCANNER INPUT]** (I C 5 -), **[COM. SCANNER OUTPUT]** (O C 5 -) submenus.

The 8 output variables and the 8 input variables are assigned by means of parameters nCA1 to nCA8 and nMA1 to nMA8. An nCAx or nMAx parameter with a value of zero is not linked to a parameter in the drive. These parameters are described in the table.

nCAx or nMAx defines the addresses to:

Sub Menu	Parameter description	Default assignment	Modbus address
[COM. SCANNER INPUT] (I C 5 -)	[Scan. IN1 address] (n P A 1) Source drive address of the 1st input word	Status (ETA)	12701 16#319D
	[Scan. IN2 address] (n P A 2) Source drive address of the 2nd input word	Output speed (RFRD)	12702 16#319E
	[Scan. IN3 address] (n P A 3) Source drive address of the 3rd input word	0	12703 16#319F
	[Scan. IN4 address] (n P A 4) Source drive address of the 4th input word	0	12704 16#31A0
	[Scan. IN5 address] (n P A 5) Source drive address of the 5th input word	0	12705 16#31A1
	[Scan. IN6 address] (n P A 6) Source drive address of the 6th input word	0	12706 16#31A2
	[Scan. IN7 address] (n P A 7) Source drive address of the 7th input word	0	12707 16#31A3
	[Scan. IN8 address] (n P A 8) Source drive address of the 8th input word	0	12708 16#31A4
[COM. SCANNER OUTPUT] (O C 5 -)	[Scan.Out1 address] (n C A 1) Destination drive address of the 1st output word	Command (CMD)	12721 16#31B1
	[Scan.Out2 address] (n C A 2) Destination drive address of the 2nd output word	Speed target (LFRD)	12722 16#31B2
	[Scan.Out3 address] (n C A 3) Destination drive address of the 3rd output word	0	12723 16#31B3
	[Scan.Out4 address] (n C A 4) Destination drive address of the 4th output word	0	12724 16#31B4
	[Scan.Out5 address] (n C A 5) Destination drive address of the 5th output word	0	12725 16#31B5
	[Scan.Out6 address] (n C A 6) Destination drive address of the 6th output word	0	12726 16#31B6
	[Scan.Out7 address] (n C A 7) Destination drive address of the 7th output word	0	12727 16#31B7
	[Scan.Out8 address] (n C A 8) Destination drive address of the 8th output word	0	12728 16#31B8

Fast Task of the Communication Scanner

Only these parameters are available for fast tasks:

Fast read	Parameters
(n P A 1) to (n P A 4)	ETA, RFR, FRH, LCR, OTR, ETI, ULN, UOP, THD, OPR, THR1, THR2, THR3, IL1I, IL1R, OL1R, AI1C, AI2C, AI3C, AO1R, AO1C, RFRD, FRHD, LRS1, LRS2, LRS3, LRS4, LRS5, LRS6, LRS7, LRS8, M001, M002, M003, M004, M005, M006, M007, M008
Fast write	Parameters
(n C A 1) to (n C A 4)	OL1R, AO1R, AO1C, CMD, LFR, PISP, LFRD, M001, M002, M003, M004, M005, M006, M007, M008

Monitoring the Communication Scanner

It is also possible to monitor the parameters value that have been configured in the communication scanner. This monitored values are accessible via the following menus: **[COMMUNICATION MAP] (C P P -)** and **[COM. SCANNER INPUT MAP] (I S A -)**, **[COM SCAN OUTPUT MAP] (D S A -)** submenu.

The 8 output variable values and the 8 input variable values are located into parameters **[Com Scan Out1 val.] (n C 1)** to **[Com Scan Out8 val.] (n C 8)** and **[Com Scan In1 val.] (n P 1)** to **[Com Scan In8 val.] (n P 8)**.

Sub Menu	Parameter description	Default assignment	Modbus address
[COM. SCANNER INPUT MAP] (I S A -)	[Com Scan In1 val.] (n P 1) Source drive value of the 1st input word	ETA value	12741 16#31C5
	[Com Scan In2 val.] (n P 2) Source drive value of the 2nd input word	RFRD value	12742 16#31C6
	[Com Scan In3 val.] (n P 3) Source drive value of the 3rd input word	0	12743 16#31C7
	[Com Scan In4 val.] (n P 4) Source drive value of the 4th input word	0	12744 16#31C8
	[Com Scan In5 val.] (n P 5) Source drive value of the 5th input word	0	12745 16#31C9
	[Com Scan In6 val.] (n P 6) Source drive value of the 6th input word	0	12746 16#31CA
	[Com Scan In7 val.] (n P 7) Source drive value of the 7th input word	0	12747 16#31CB
	[Com Scan In8 val.] (n P 8) Source drive value of the 8th input word	0	12748 16#31CC
[COM SCAN OUTPUT MAP] (D S A -)	[Com Scan Out1 val.] (n C 1) Destination drive value of the 1st output word	CMD value	12761 16#31D9
	[Com Scan Out2 val.] (n C 2) Destination drive value of the 2nd output word	LFRD value	12762 16#31DA
	[Com Scan Out3 val.] (n C 3) Destination drive value of the 3rd output word	0	12763 16#31DB
	[Com Scan Out4 val.] (n C 4) Destination drive value of the 4th output word	0	12764 16#31DC
	[Com Scan Out5 val.] (n C 5) Destination drive value of the 5th output word	0	12765 16#31DD
	[Com Scan Out6 val.] (n C 6) Destination drive value of the 6th output word	0	12766 16#31DE
	[Com Scan Out7 val.] (n C 7) Destination drive value of the 7th output word	0	12767 16#31DF
	[Com Scan Out8 val.] (n C 8) Destination drive value of the 8th output word	0	12768 16#31E0

Configuring Monitor Parameters

These parameters are visible only with the graphic display terminal.

Up to 4 parameters can be selected and their value displayed in the **[1.2 MONITORING]** menu on the graphic display terminal (to be order separately - reference VW3 A1 101).

The selection is made via the **[3. INTERFACE] / [3.3 MONITORING CONFIG.]** menu (**[COM. MAP CONFIG.]** submenu).

Each of the parameters **[Word 1 add. select.] ... [Word 4 add. select.]** can be used to select the logic address of the parameter. An address at zero is used to disable the function.

Example

In the example given here, the monitored words are:

- Parameter 1 = Motor current (LCR): Logic address 3204; signed decimal format
- Parameter 2 = Motor torque (OTR): Logic address 3205; signed decimal format
- Parameter 3 = Last detected fault (LFT): Logic address 7121; hexadecimal format
- Disabled parameter: Address W0; default format: Hexadecimal format

RDY	MDB	+0.00Hz	0A
COM.. MAP CONFIG.			
Address 1 select	:		3204
Format address 1	:		Signed
Address 2 select	:		3205
Format address 2	:		Signed
Address 3 select	:		7121
Code		Quick	
Format address 3	:		Hex
Address 4 select	:		0
Format address 3	:		Hex

One of the three display formats below can be assigned to each monitored word:

Format	Range	Terminal display
Hexadecimal	0000 ... FFFF	[Hex]
Signed decimal	-32 768 ... 32 767	[Signed]
Unsigned decimal	0 ... 65 535	[Unsigned]

NOTE: If a monitored parameter:

- has been assigned to an unknown address,
- has been assigned to a protected parameter,
- has not been assigned,

the value displayed on the **[COMMUNICATION MAP]** screen will be “***” (See “Diagnostics” on page 20.)

Configuring Communication Interruption Management

If the drive does not receive any Modbus request sent to its address for a predefined period of time (time out), a Modbus detected fault is triggered.

The “time out” can be set to between 0.1 and 30 s using the graphic display terminal or integrated display terminal via the **[Modbus time out]** (E E D) parameter in the **[COMMUNICATION]** (C D P -) menu (**[MODBUS NETWORK]** (P d I -) submenu). The default value is 10 s.

Configuration can be performed using the graphic display terminal or integrated display terminal via the **[Modbus fault mgt]** (S L L) parameter in the **[FAULT MANAGEMENT]** (F L E -) menu (**[COM. FAULT MANAGEMENT]** (E L L -) submenu).

RDY	MDB	+0.00Hz	0A
COM. FAULT MANAGEMENT			
Network fault mgt	:	Freewheel	
CANopen fault mgt	:	Freewheel	
Modbus fault mgt	:	Freewheel	
Code		Quick	

The values of the **[Modbus fault mgt]** (S L L) parameter, which trigger a drive detected fault **[Modbus com.]** (S L F I), are:

Value	Meaning
[Freewheel] (Y E S)	Freewheel stop (factory setting)
[Ramp stop] (r P P)	Stop on ramp
[Fast stop] (F S E)	Fast stop
[DC injection] (d E I)	DC injection stop

The values of the **[Modbus fault mgt]** (S L L) parameter, which do not trigger a drive detected fault, are:

Value	Meaning
[Ignore] (n D)	Detected fault ignored.
[Per STT] (S E E)	Stop according to configuration of [Type of stop] (S E E).
[fallback speed] (L F F)	Change to fallback speed, maintained as long as the detected fault persists and the run command has not been removed.
[Spd maint.] (r L S)	The drive maintains the speed at the time the detected fault occurred, as long as the detected fault persists and the run command has not been removed.

The fallback speed can be configured in the **[FAULT MANAGEMENT]** (F L E -) / **[FALLBACK SPEED]** (L F F -) menu using the **[Fallback speed]** (L F F) parameter.

▲ WARNING

LOSS OF CONTROL

If Modbus fault management **[Modbus fault mgt]** (S L L) is set to **[Ignore]** (n D), communication control will be inhibited.

For safety reasons, inhibiting the communication interruption detection should be restricted to the debug phase or to special applications.

Failure to follow these instructions can result in death, serious injury, or equipment damage.

Diagnostics



3

What's in this Chapter?

This chapter contains the following topics:

Topic	Page
Communication Diagnostics	21
Modbus Counters	21
Modbus Communication Stat	21

Communication Diagnostics

These parameters are visible only with the graphic display terminal.

On the terminal, in the **[1.2 MONITORING]** menu (**[COMMUNICATION MAP]** (C P P -) submenu):

The **[MODBUS NETWORK DIAG]** (P n d -) submenu can be used to display the status of Modbus network communications.

RUN	MDB	+50.00Hz	80A
MODBUS NETWORK DIAG			<input type="checkbox"/>
COM LED	:		⊗
Mb net frames nb.	:		568
Mb net crc errors	:		0
Code		Quick	<input type="checkbox"/>

⊗ Indicates a LED, which is not lit.

Modbus Counters

- **[Mb NET frames nb.]** (P I C E) indicate the number of Modbus frames received. The counter counts both correct and incorrect frames.
- **[Mb NET CRC errors]** (P I E C) indicate the number of Modbus frames containing checksum errors.

In the case of these two counters, only frames that are destined for the drive and whose Modbus address is supplied by the **[Modbus Address]** (P d d) parameter are counted. Broadcast frames are not counted.

[Mb NET frames nb.] (P I C E) is modulo 65 536 counters, i.e., the value is reset to zero once the value of 65 535 is reached.

By contrast, the **[Mb NET CRC errors]** (P I E C) remain at 65 535 once this value is reached.

Each Modbus counter corresponds to a drive parameter:

Menu	Parameter name	Code	Logical address
[MODBUS NETWORK DIAG]	[Mb NET frames nb.]	(P I C E)	6011
	[Mb NET CRC errors]	(P I E C)	6010

Modbus Communication Stat

This can be accessed from the menu:

[1.3 CONF] (C D n F) / **[FULL]** (F U L L) / **[COMMUNICATION]** (C D P -) / **[MODBUS NETWORK]** (P d I -) / **[Mdb com stat]** (C D P I)

(r D E D): Modbus no reception, no transmission = communication idle

(r D E I): Modbus no reception, transmission

(r I E D): Modbus reception, no transmission

(r I E I): Modbus reception and transmission

Profiles



4

What's in this Chapter?

This chapter contains the following topics:

Topic	Page
Definition of a Profile	23
Functional Profiles Supported by the Altivar 32	24

Definition of a Profile

There are three types of profile:

- Communication profiles
- Functional profiles
- Application profiles

Communication Profiles

A communication profile describes the characteristics of the bus or network:

- Cables
- Connectors
- Electrical characteristics
- Access protocol
- Addressing system
- Periodic exchange service
- Messaging service
- ...

A communication profile is unique to a type of network (Modbus CIP, Profibus DP, etc.) and is used by various different types of device.

Functional Profiles

A functional profile describes the behavior of a type of device. It defines:

- Functions
- Parameters (name, format, unit, type, etc.)
- Periodic I/O variables
- State chart(s)
- ...

A functional profile is common to all members of a device family (variable speed drives, encoders, I/O modules, displays, etc.).

They can feature common or similar parts. The standardized (IEC 61800-7) functional profiles of variable speed drives are:

- CiA402
- PROFIDRIVE
- CIP

DRIVECOM has been available since 1991.

CiA402 "Device profile for drives and motion control" represents the next stage of this standard's development and is now part of the IEC 61800-7 standard.

Some protocols also support the ODVA (Open DeviceNet Vendor Association) profile.

Application Profiles

Application profiles define in their entirety the services to be provided by the devices on a machine. For example, "CiA DSP 417-2 V 1.01 part 2: CANopen application profile for lift control systems - virtual device definitions".

Interchangeability

The aim of communication and functional profiles is to achieve interchangeability of the devices connected via the network.

Functional Profiles Supported by the Altivar 32

I/O Profile

Using the I/O profile simplifies PLC programming.

The I/O profile mirrors the use of the terminal strip for control by utilizing 1 bit to control a function.

With an Altivar 32, the I/O profile can also be used when controlling via a network.

The drive starts up as soon as the run command is sent.

15 bits of the control word (bits 1 to 15) can be assigned to a specific function.

This profile can be developed for simultaneous control of the drive via:

- The terminals
- The Modbus control word
- The CANopen control word
- The network module control word

The I/O profile is supported by the drive itself and therefore in turn by all the communication ports (integrated Modbus, CANopen, Ethernet, Profibus DP, DeviceNet communication modules).

CiA402 Profile

The drive only starts up following a command sequence.

The control word is standardized.

5 bits of the control word (bits 11 to 15) can be assigned to a function.

The CiA402 profile is supported by the drive itself and therefore in turn by all the communication ports (integrated Modbus, CANopen, Ethernet, Profibus DP, DeviceNet communication modules).

The Altivar 32 supports the CiA402 profile's "Velocity mode".

In the CiA402 profile, there are two modes that are specific to the Altivar 32 and characterize command and reference management:

- Separate mode **[Separate] (SEP)**
- Not separate mode **[Not separ.] (IN)**

See "CiA402 - IEC61800-7 Functional Profile" on page 25.

CiA® 402 - IEC61800-7 Functional Profile

5

What's in this Chapter?

This chapter contains the following topics:

Topic	Page
Functional Description	26
CiA402 State Chart	27
Description of States	28
Summary	29
Control Word (CMd)	30
Stop Commands	31
Assigning Control Word Bits	31
Status Word (EtA)	32
Starting Sequence	33
Sequence for a Drive Powered by the Power Section Line Supply	34
Sequence for a Drive With Separate Control Section	36
Sequence for a Drive with Line Contactor Control	39

Functional Description

Drive operation involves two main functions, which are illustrated in the diagrams below:

CiA402

The main parameters are shown with their CiA402 name and their CiA402/Drivecom index (the values in brackets are the CANopen addresses of the parameter).

Control diagram:

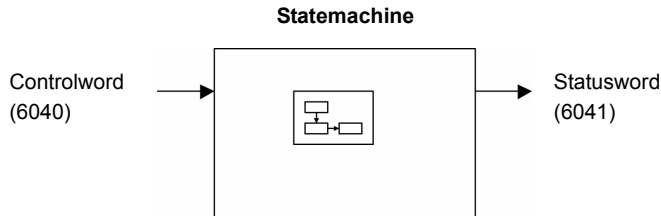

Simplified diagram of speed control in “Velocity” mode:

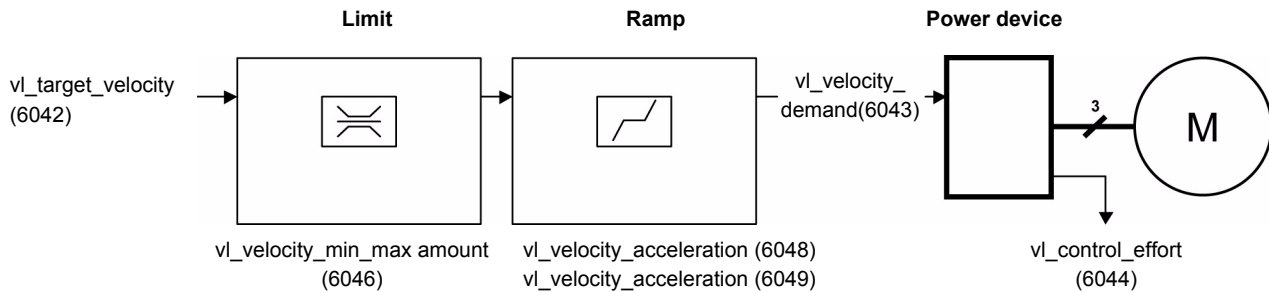

Altivar 32

These diagrams translate as follows for the Altivar system:

Control diagram:

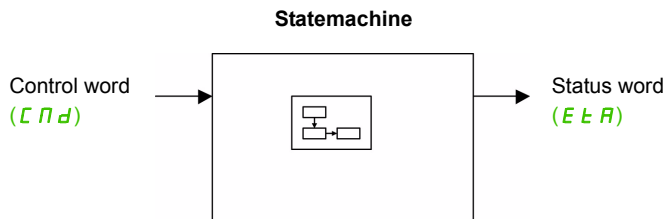

Simplified diagram of speed control in “Velocity” mode:

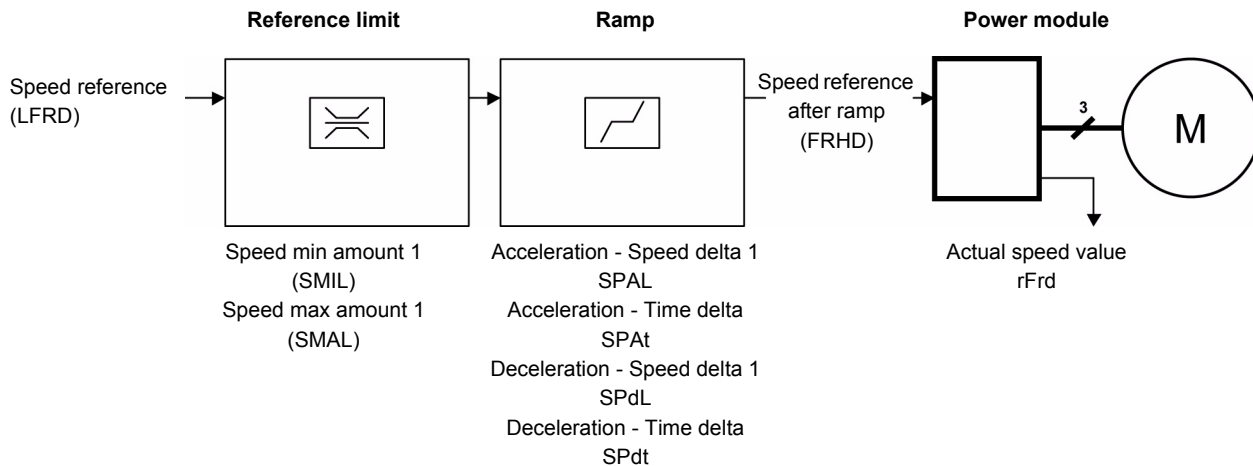

Description of States

Each state represents an internal reaction by the drive.

This chart will change depending on whether the control word is sent (**C P d**) or an event occurs (a detected fault, for example).

The drive state can be identified by the value of the status word (**E L R**).

State	Drive internal reaction
1 - Not ready to switch on	Initialization starts. This is a transient state invisible to the communication network.
2 - Switch on disabled	<p>The drive is inactive.</p> <p>The drive is locked, no power is supplied to the motor.</p> <p>For a separate control section, it is not necessary to supply AC power to the power section.</p> <p>For a separate control section with line contactor, the contactor is not controlled.</p> <p>The configuration and adjustment parameters can be modified.</p>
3 - Ready to switch on	<p>Awaiting power section line supply.</p> <p>For a separate control section, it is not necessary to supply AC power to the power section, but the system will expect it in order to change to state "4 - Switched on".</p> <p>For a separate control section with line contactor, the contactor is not controlled.</p> <p>The drive is locked, no power is supplied to the motor.</p> <p>The configuration and adjustment parameters can be modified.</p>
4 - Switched on	<p>The drive is supplied with AC power but is stationary.</p> <p>For a separate control section, the power section line supply must be present.</p> <p>For a separate control section with line contactor, the contactor is controlled.</p> <p>The drive is locked, no power is supplied to the motor.</p> <p>The power stage of the drive is ready to operate, but voltage has not yet been applied to the output.</p> <p>The adjustment parameters can be modified.</p> <p>Modification of a configuration parameter returns the drive to state "2 - Switch on disabled".</p>
5 - Operation enabled	<p>The drive is running.</p> <p>For a separate control section, the power section line supply must be present.</p> <p>For a separate control section with line contactor, the contactor is controlled.</p> <p>The drive is unlocked, power is supplied to the motor.</p> <p>The drive functions are activated and voltage is applied to the motor terminals.</p> <p>However, in the case of an open-loop drive, if the reference is zero or the "Halt" command is applied, no power is supplied to the motor and no torque is applied.</p> <p>[Auto tuning] (E U n) requires an injection of current into the motor. The drive must therefore be in state "5 - Operation enabled" for this command.</p> <p>The adjustment parameters can be modified.</p> <p>The configuration parameters cannot be modified.</p> <p>NOTE: the command "4 - Enable operation" must be taken into consideration only if the channel is valid. In particular, if the channel is involved in the command and the reference, transition 4 will take place only after the reference has been received for the first time.</p> <p>The reaction of the drive to a "Disable operation" command depends on the value of the [Dis. operat opt code] (d D E d) parameter:</p> <ul style="list-style-type: none"> - If the [Dis. operat opt code] (d D E d) parameter has the value 0, the drive changes to "4 - Switched on" and stops in freewheel stop. - If the [Dis. operat opt code] (d D E d) parameter has the value 1, the drive stops on ramp and then changes to "4 - Switched on".
6 - Quick stop active	<p>Emergency stop</p> <p>The drive performs a fast stop, after which restarting will only be possible once the drive has changed to the "Switch on disabled" state.</p> <p>During fast stop, the drive is unlocked and power is supplied to the motor.</p> <p>The configuration parameters cannot be modified.</p> <p>The condition for transition 12 to state "2 - Switch on disabled" depends on the value of the parameter Quick stop mode (QStd):</p> <p>If the Quick stop mode parameter has the value FST2, the drive stops according to the fast stop ramp and then changes to state "2 - Switch on disabled".</p> <p>If the Quick stop mode parameter has the value FST6, the drive stops according to the fast stop ramp and then remains in state "6 - Quick stop active" until:</p> <ul style="list-style-type: none"> - A "Disable voltage" command is received. - Or the STOP key is pressed. - Or there is a freewheel stop command via the terminals.

State	Drive internal reaction
7 - Fault reaction active	Transient state during which the drive performs an action appropriate to the type of detected fault. The drive function is activated or deactivated according to the type of reaction configured in the detected fault management parameters.
8 - Fault	Drive has detected a fault. The drive is locked, no power is supplied to the motor.

Summary

State	Power section line supply for separate control section	Power supplied to motor	Modification of configuration parameters
1 - Not ready to switch on	Not required	No	Yes
2 - Switch on disabled	Not required	No	Yes
3 - Ready to switch on	Not required	No	Yes
4 - Switched on	Required	No	Yes, return to "2 - Switch on disabled" state
5 - Operation enabled	Required	Yes, apart from an open-loop drive with a zero reference or in the event of a "Halt" command for an open-loop drive.	No
6 - Quick stop active	Required	Yes, during fast stop	No
7 - Fault reaction active	Depends on detected fault management configuration	Depends on detected fault management configuration	-
8 - Fault	Not required	No	Yes

Control Word (CWD)

bit 7	bit 6	bit 5	bit 4	bit 3	bit 2	bit 1	bit 0
Fault reset	Reserved (=0)	Reserved (=0)	Reserved (=0)	Enable operation	Quick stop	Enable voltage	Switch on
0 to 1 transition = Ack. fault				1 = Run command			

bit 15	bit 14	bit 13	bit 12	bit 11	bit 10	bit 9	bit 8
MANUFACTURER SPECIFIC Assignable	MANUFACTURER SPECIFIC Assignable	MANUFACTURER SPECIFIC Assignable	MANUFACTURER SPECIFIC Assignable	Manufacturer specific	Reserved (=0)	Reserved (=0)	Halt
				0 = Forward direction asked 1 = Reverse direction asked			Halt

Command	Transition address	Final state	bit 7	bit 3	bit 2	bit 1	bit 0	Example value
			Fault reset	Enable operation	Quick stop	Enable voltage	Switch on	
Shutdown	2, 6, 8	3 - Ready to switch on	x	x	1	1	0	16#0006
Switch on	3	4 - Switched on	x	x	1	1	1	16#0007
Enable operation	4	5 - Operation enabled	x	1	1	1	1	16#000F
Disable operation	5	4 - Switched on	x	0	1	1	1	16#0007
Disable voltage	7, 9, 10, 12	2 - Switch on disabled	x	x	x	0	x	16#0000
Quick stop	11	6 - Quick stop active	x	x	0	1	x	16#0002
	7, 10	2 - Switch on disabled						
Fault reset	15	2 - Switch on disabled	0 → 1	x	x	x	x	16#0080

x: Value is of no significance for this command.

0 → 1: Command on rising edge.

Stop Commands

The “Halt” command enables movement to be interrupted without having to leave the “5 - Operation enabled” state. The stop is performed in accordance with the **[Type of stop] (S E E)** parameter.

If the “Halt” command is active, power is supplied to the motor and torque can be applied during “Halt” state through DC injection when ADC = CT or LI DCI active.

Regardless of the assignment of the **[Type of stop] (S E E)** parameter (**[Fast stop assign] (F S E)**, **[Ramp stop] (r P P)**, **[Freewheel] (r S E)**, or **[DC injection assign.] (d C I)**), the drive remains in the “5 - Operation enabled” state.

A Fast Stop command at the terminals or using a bit of the control word assigned to Fast Stop causes a change to the “4 - Switched on” state. A “Halt” command does not cause this transition.

A Freewheel Stop command at the terminals or using a bit of the control word assigned to Freewheel Stop causes a change to the “2 - Switch on disabled” state. A “Halt” command does not cause this transition.

Assigning Control Word Bits

In the CiA402 profile, fixed assignment of a function input is possible using the following codes:

Bit	Integrated Modbus
bit 11	C111
bit 12	C112
bit 13	C113
bit 14	C114
bit 15	C115

For example, to assign the DC injection braking to bit 13 of Modbus, simply configure the **[DC injection assign.] (d C I)** parameter with the **[C113] (C I I 3)** value.

Bit 11 is assigned by default to the operating direction command **[Reverse assign.] (r r 5)**.

Status Word (E L F)

bit 7	bit 6	bit 5	bit 4	bit 3	bit 2	bit 1	bit 0
Warning	Switch on disabled	Quick stop	Voltage enabled	Fault	Operation enabled	Switched on	Ready to switch on
Alarm	Power section line supply disabled	0 = Emergency stop	Power section line supply present	Fault	Running	Ready	1 = Awaiting power section line supply

bit 15	bit 14	bit 13	bit 12	bit 11	bit 10	bit 9	bit 8
Manufacturer specific Direction of rotation	MANUFACTURER SPECIFIC Stop via STOP key	Reserved (=0)	Reserved (=0)	Internal limit active	Target reached	Remote	Reserved (=0)
				Reference outside limits	Reference reached	Command or reference via network	

Status	bit 6	bit 5	bit 4	bit 3	bit 2	bit 1	bit 0	ETA masked by 16#006F ⁽¹⁾
	Switch on disabled	Quick stop	Voltage enabled	Fault	Operation enabled	Switched on	Ready to switch on	
1 -Not ready to switch on	0	x	x	0	0	0	0	-
2 -Switch on disabled	1	x	x	0	0	0	0	16#0040
3 -Ready to switch on	0	1	x	0	0	0	1	16#0021
4 -Switched on	0	1	1	0	0	1	1	16#0023
5 -Operation enabled	0	1	1	0	1	1	1	16#0027
6 -Quick stop active	0	0	1	0	1	1	1	16#0007
7 -Fault reaction active	0	x	x	1	1	1	1	-
8 -Fault	0	x	x	1	0	0	0	16#0008 ⁽²⁾ or 16#0028

(1) This mask can be used by the PLC program to test the chart state.

(2) Detected fault following state "6 - Quick stop active".

x: In this state, the value of the bit can be 0 or 1.

Starting Sequence

The command sequence in the state chart depends on how power is being supplied to the drive.

There are three possible scenarios:

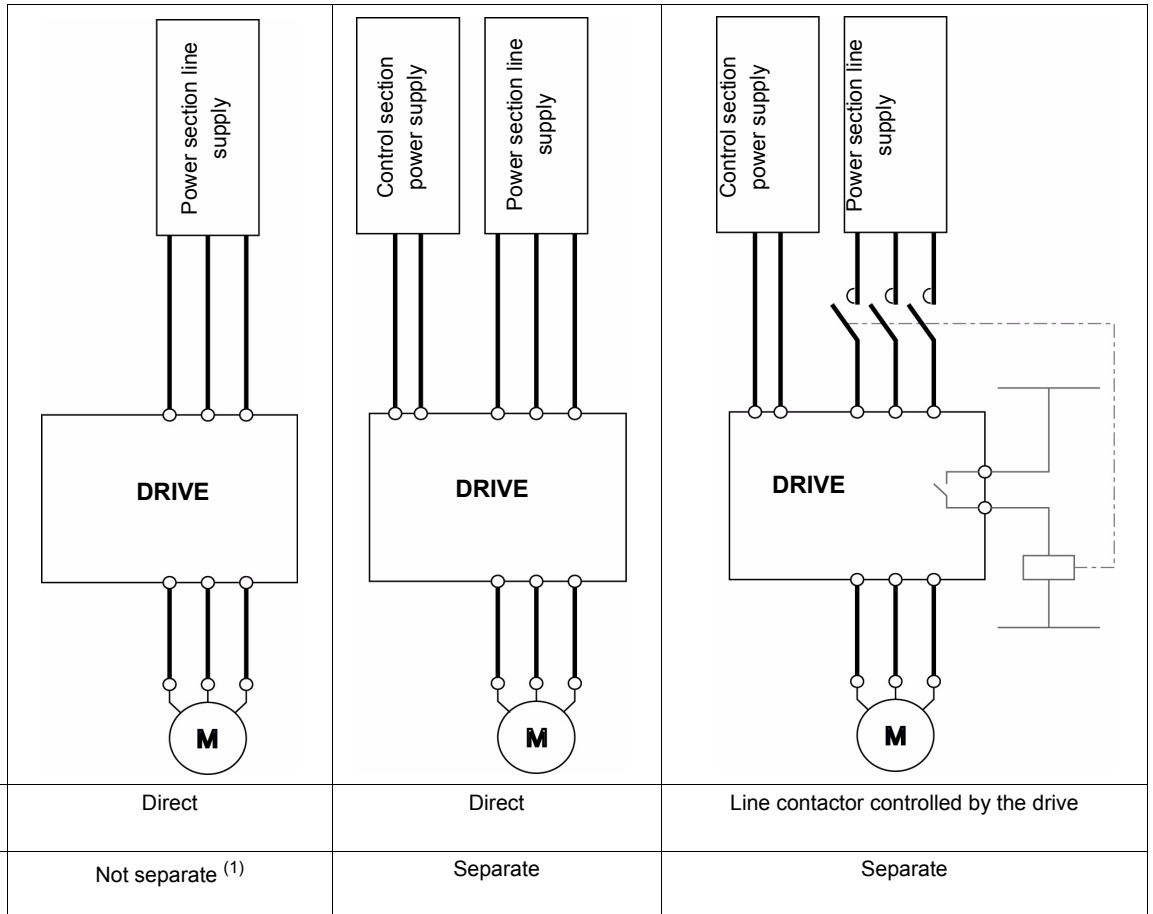

(1) The power section supplies the control section.

Sequence for a Drive Powered by the Power Section Line Supply

Both the power and control sections are powered by the power section line supply.
 If power is supplied to the control section, it has to be supplied to the power section as well.
 The following sequence must be applied:

Step 1

Send the "2 - Shutdown" command

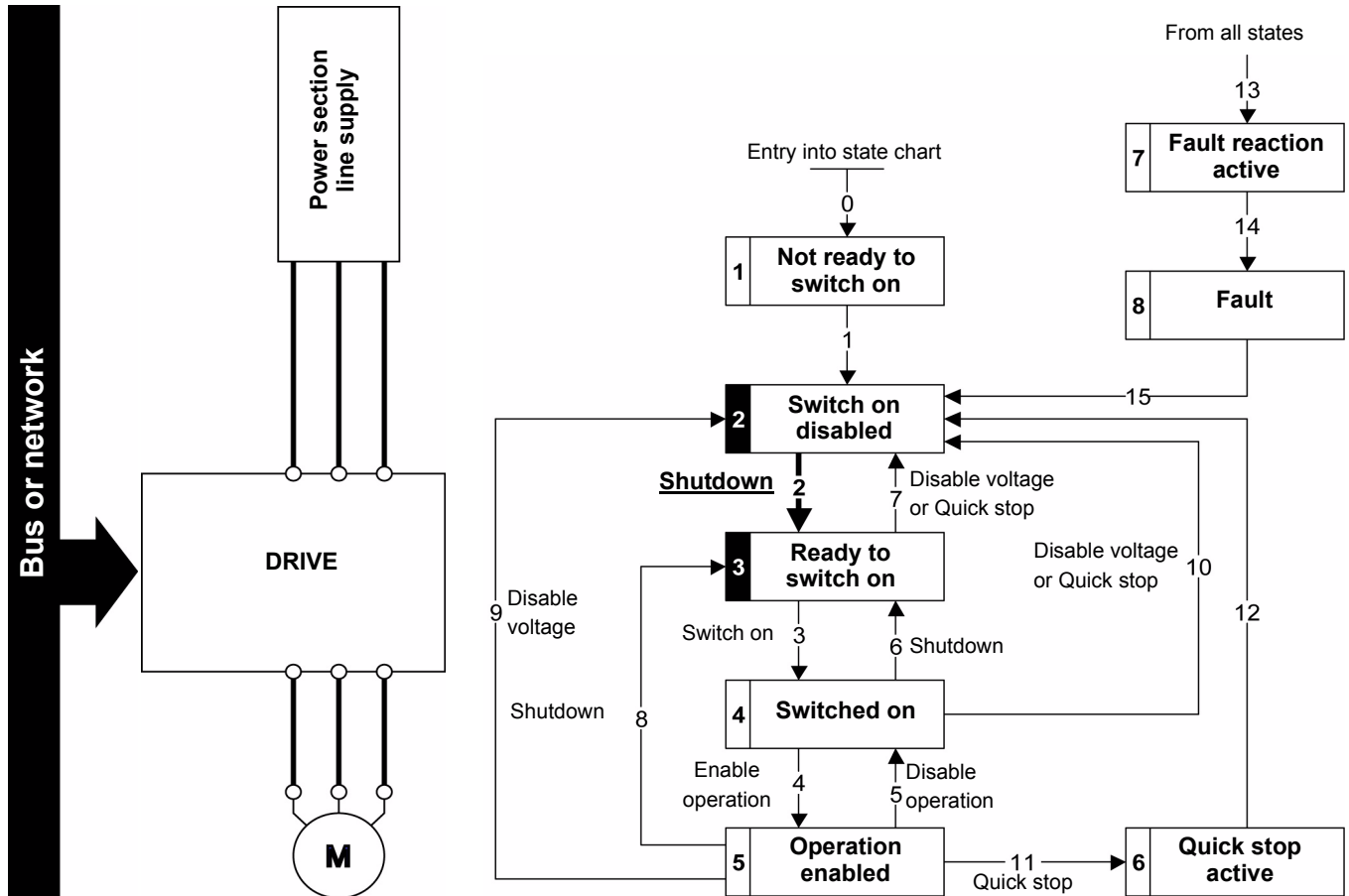

Step 2

- Check that the drive is in the “3 - Ready to switch on” state.
- Then send the “4 - Enable operation” command.
- The motor can be controlled (send a reference not equal to zero).

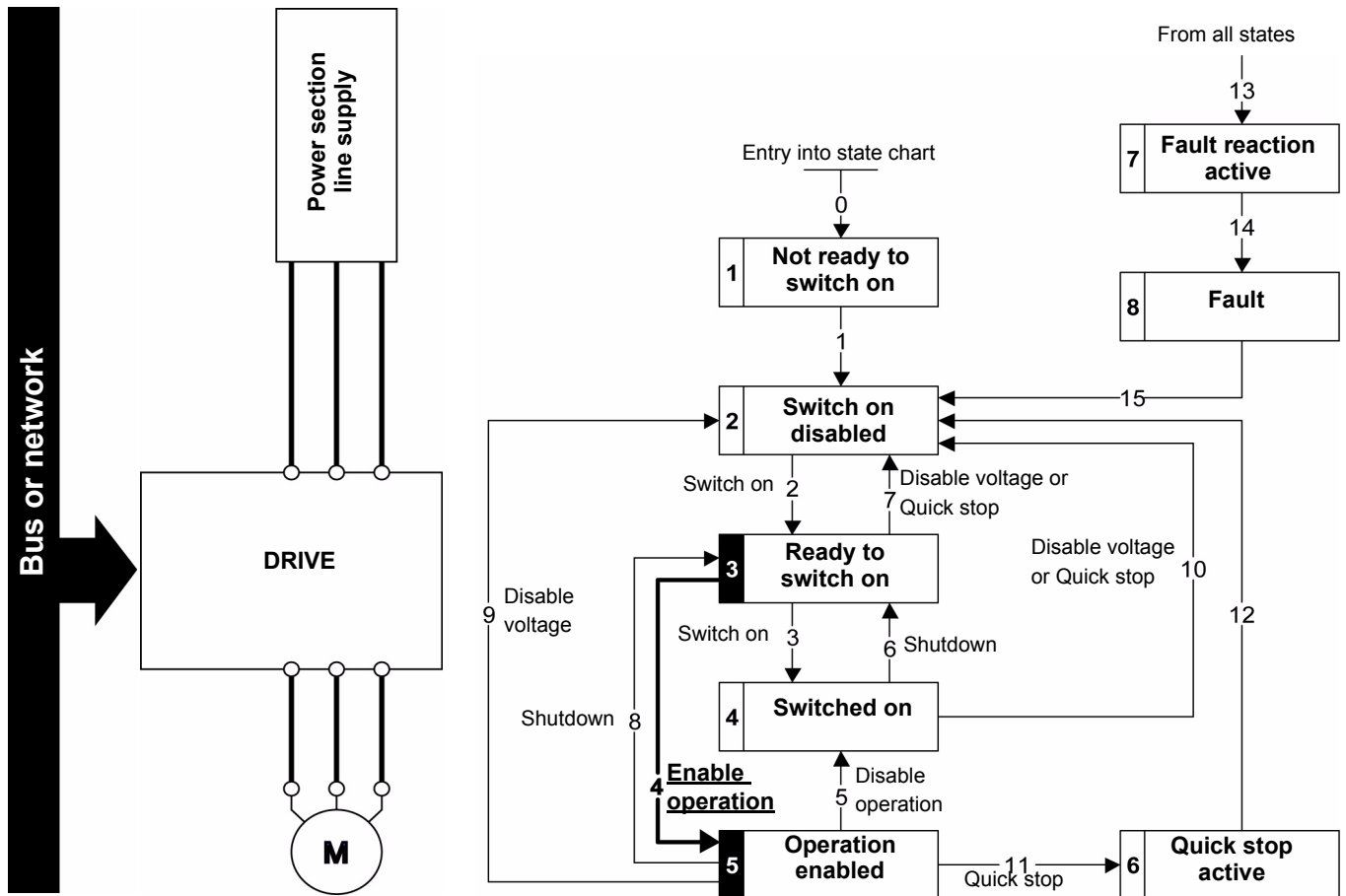

NOTE: it is possible, but not necessary, to send the “3 - Switch on” command followed by the “4 - Enable Operation” command to switch successively into the states “3 - Ready to Switch on”, “4 - Switched on” and then “5 - Operation Enabled”.
The “4 - Enable operation” command is sufficient.

Sequence for a Drive With Separate Control Section

Power is supplied separately to the power and control sections.

If power is supplied to the control section, it does not have to be supplied to the power section as well.

The following sequence must be applied:

Step 1

- The power section line supply is not necessarily present.
- Send the “2 - Shutdown” command

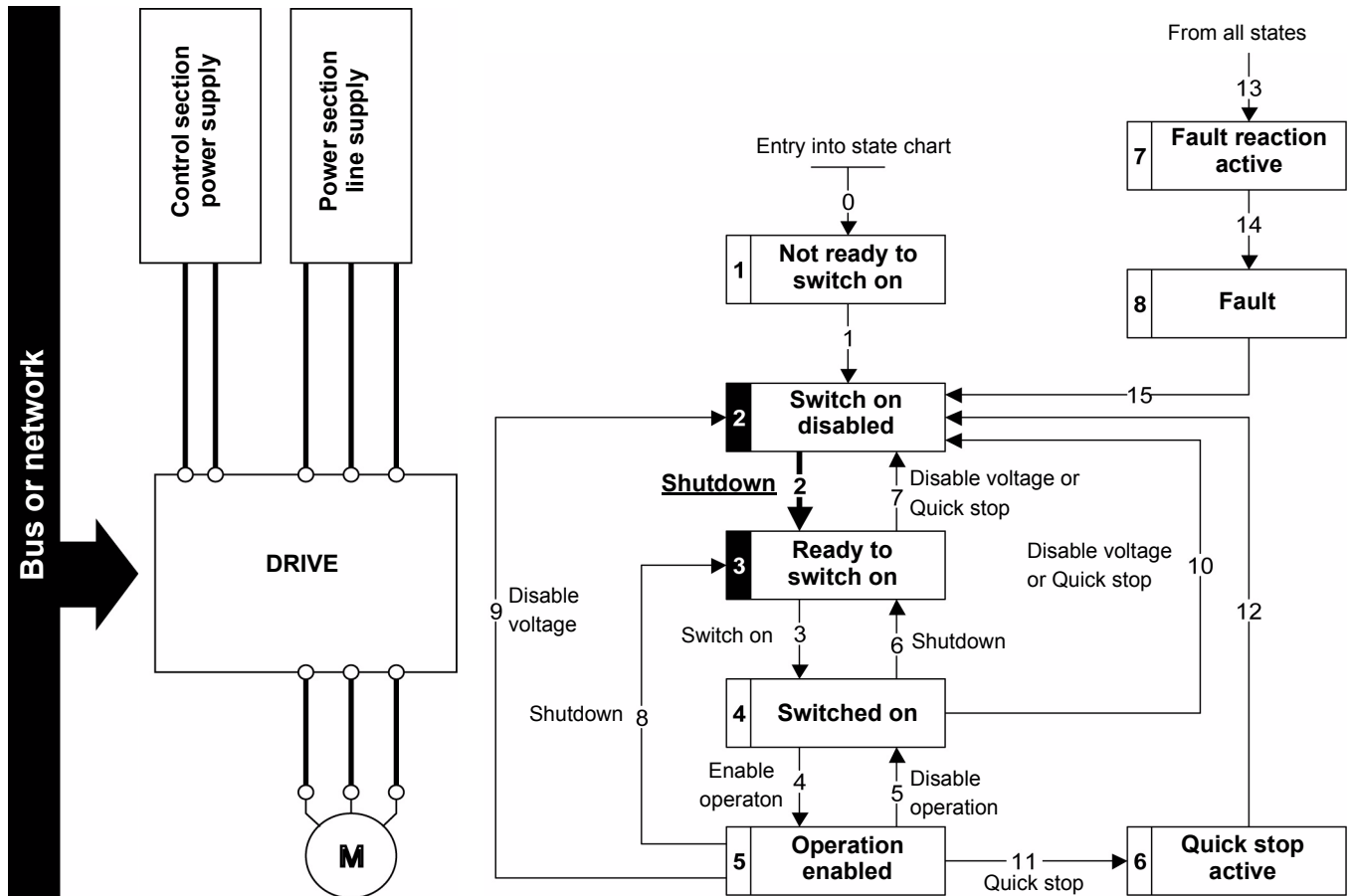

Step 2

- Check that the drive is in the “3 - Ready to switch on” state.
- Check that the power section line supply is present (“Voltage enabled” of the status word).

Power section line supply	Terminal display	Status word
Absent	<i>n L P</i>	16#●●21
Present	<i>r d Y</i>	16#●●31

- Send the “3 - Switch on” command

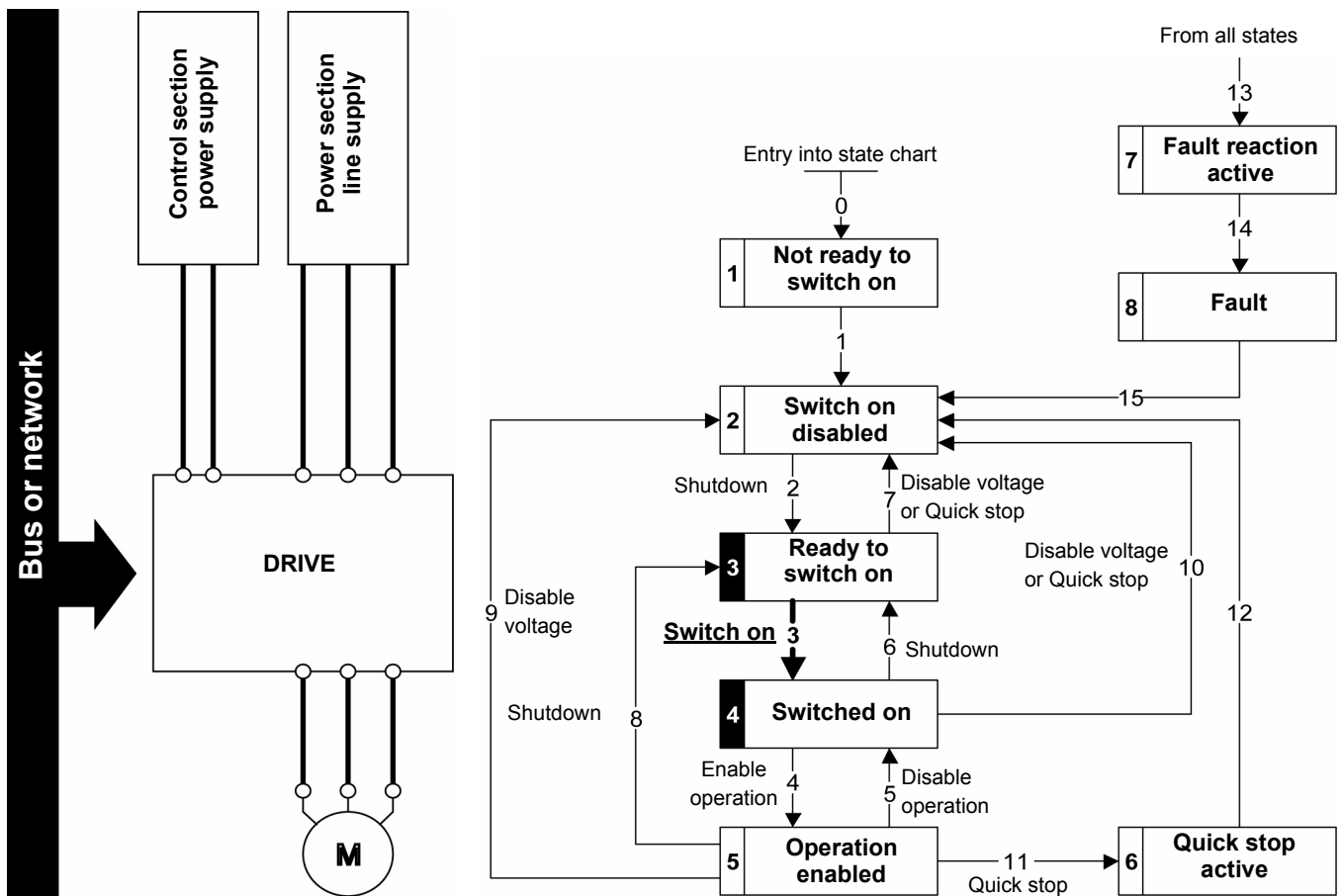

Step 3

- Check that the drive is in the “4 - Switched on” state.
- Then send the “4 - Enable operation” command.
- The motor can be controlled (send a reference not equal to zero).
- If the power section line supply is still not present in the “4 - Switched on” state after a time delay **[Mains V. time out] (L C E)**, the drive will switch to detected fault mode **[input contactor] (L C F)**.

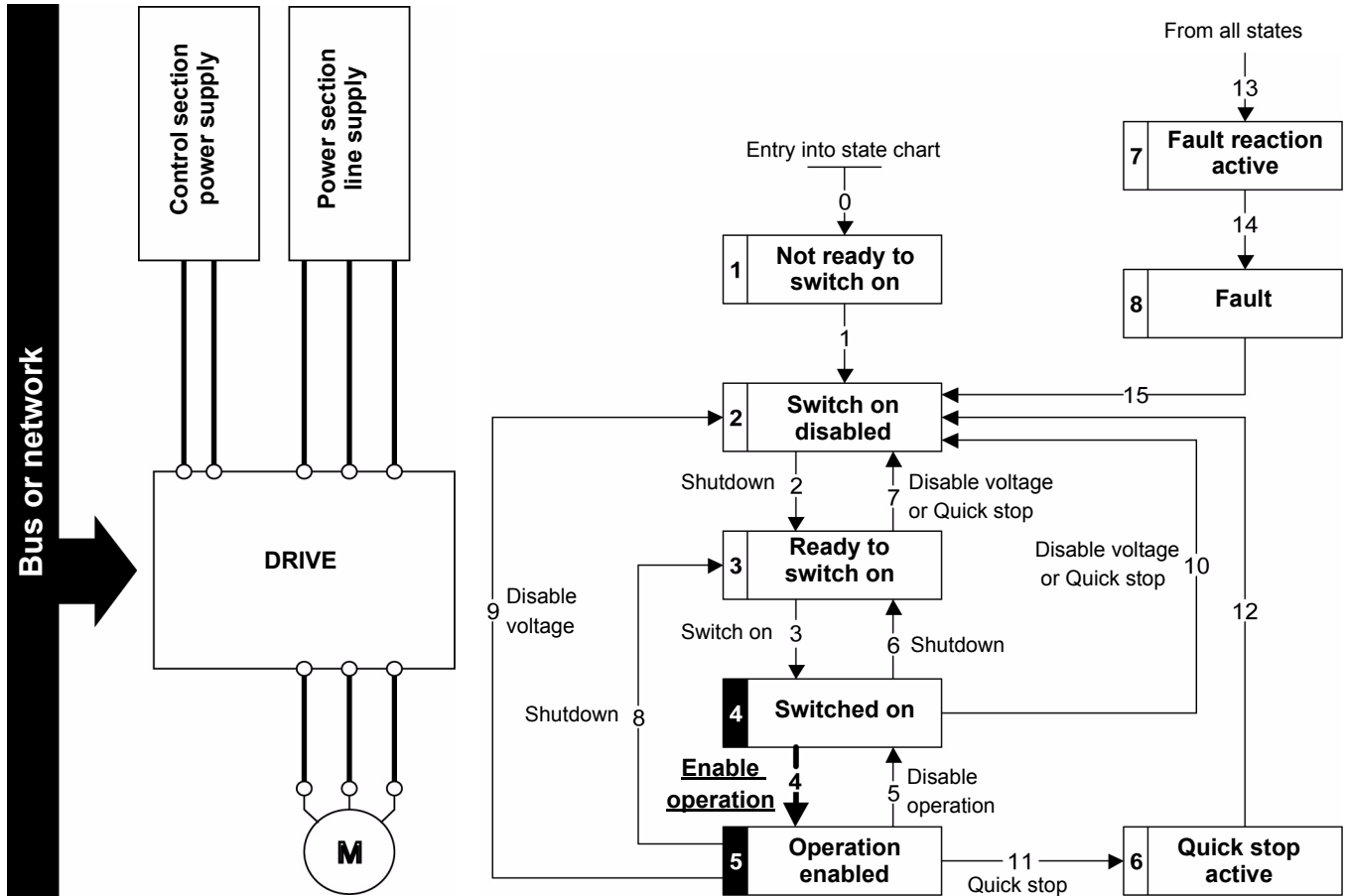

Sequence for a Drive with Line Contactor Control

Power is supplied separately to the power and control sections.

If power is supplied to the control section, it does not have to be supplied to the power section as well. The drive controls the line contactor.

The following sequence must be applied:

Step 1

- The power section line supply is not present as the line contactor is not being controlled.
- Send the “2 - Shutdown” command

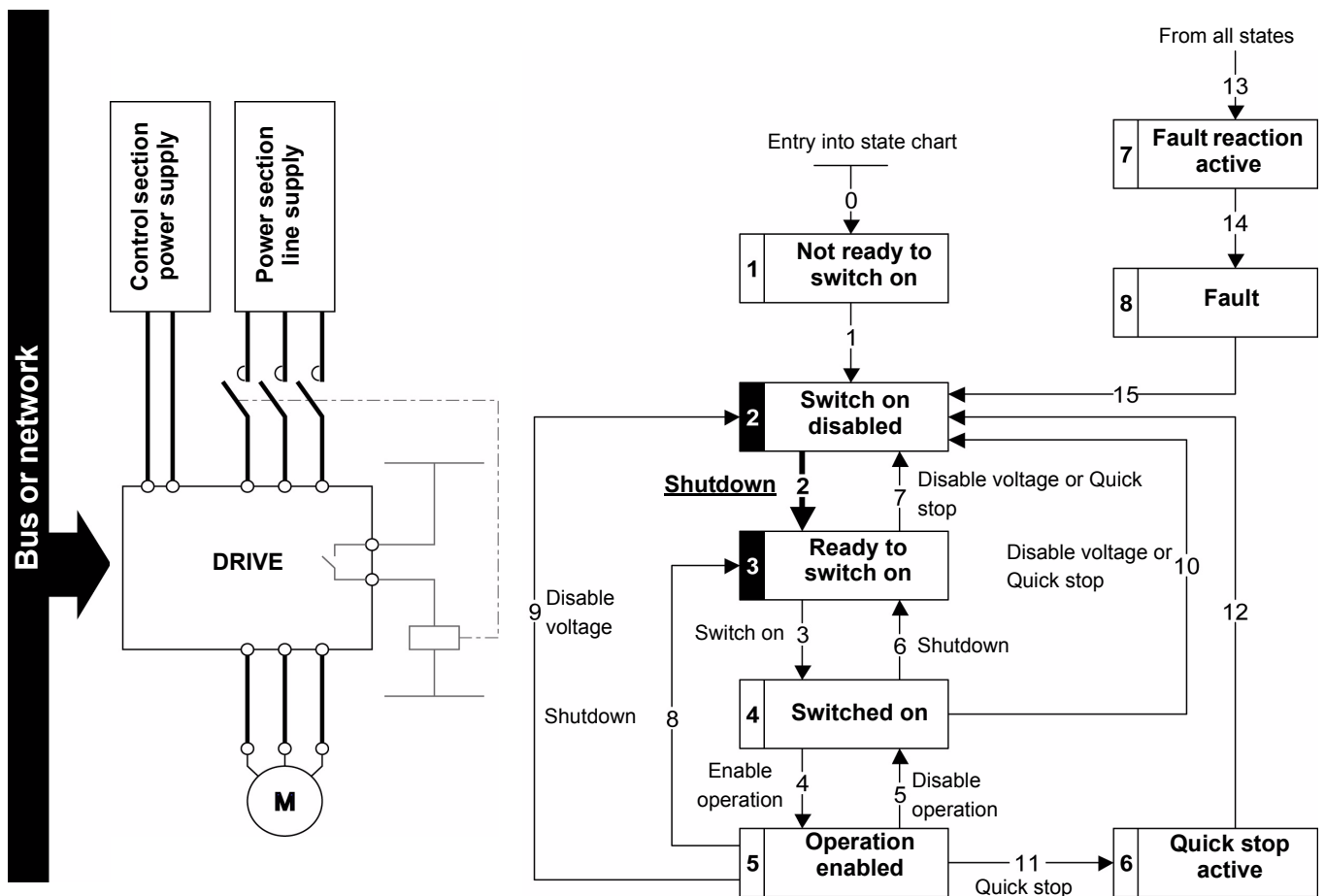

Step 2

- Check that the drive is in the “3 - Ready to switch on” state.
- Send the “3 - Switch on” command, which will close the line contactor and switch on the power section line supply.

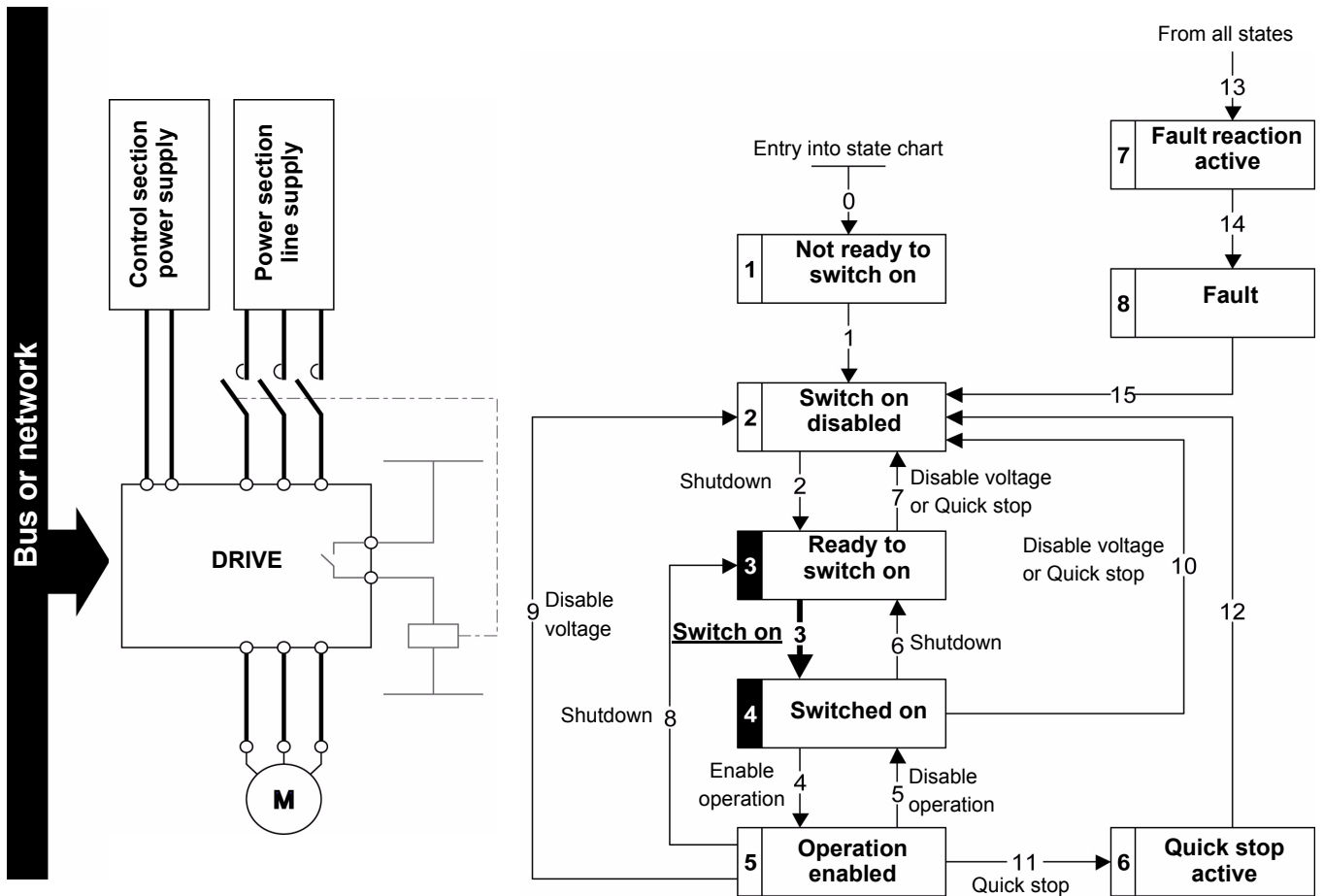

Software Setup with Unity (M340)



6

What's in this Chapter?

This chapter contains the following topics:

Topic	Page
Introduction	42
Drive Configuration	43
Modbus Master Configuration	44

Introduction

Here is an example of an application that shows how to control an ATV32 with a M340 PLC equipped with a Modbus master serial port. The operator can control the drive directly from Unity. The version of Unity used here is Unity Pro XL V4.0.

In the example, the communication scanner of the ATV32 is used. The PLC will send the command and the speed reference to the ATV32 and will read the status word and the actual speed of the drive.

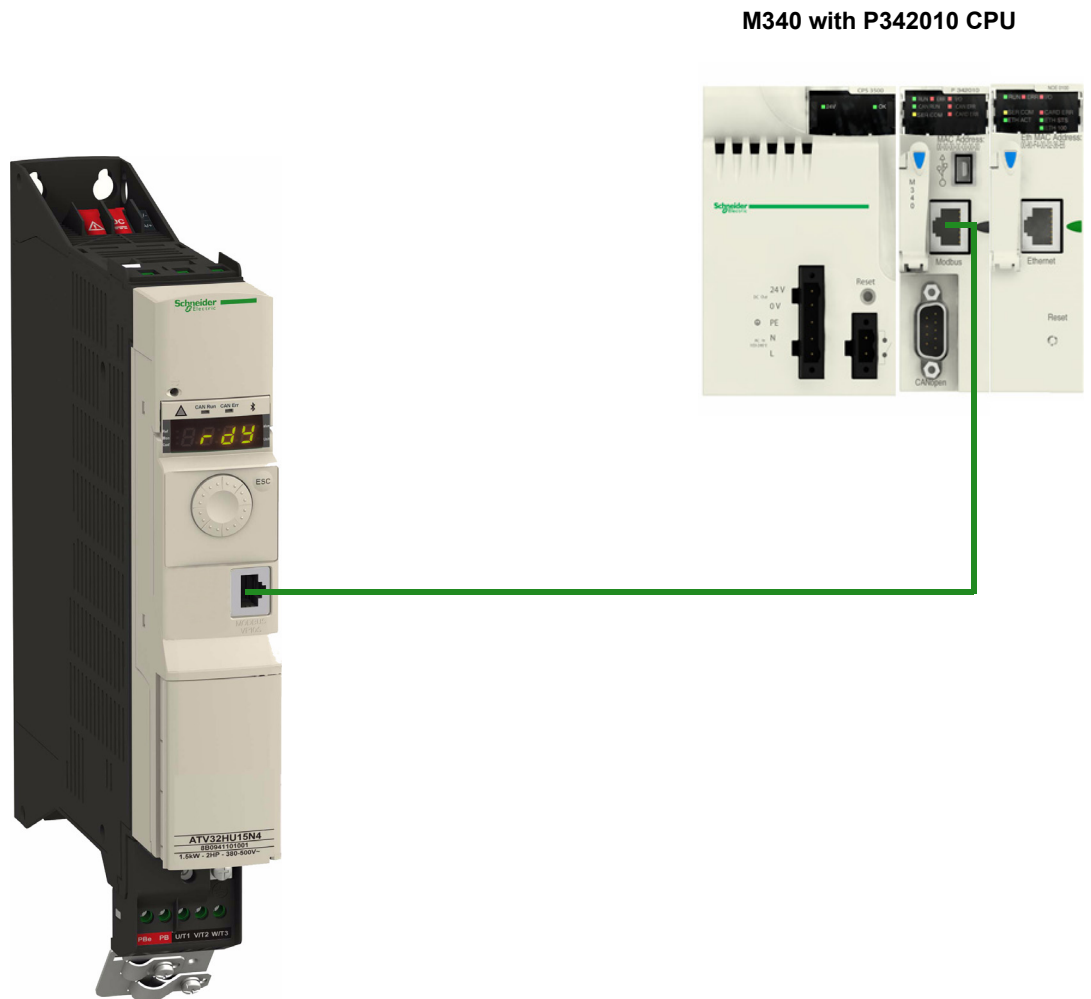

Drive Configuration

Factory Setting

Before configuring the drive, it's strongly advised to make a factory setting. Goto to:

- **[1.3 CONFIGURATION]** (C D n F) menu,
- **[FACTORY SETTINGS]** (F L 5 -) sub-menu.

Then configure the following parameters:

- **[PARAMETER GROUP LIST]** (F r Y -) = **[All]** (A I I)
- **[Goto FACTORY SETTINGS]** (G F 5) = enter

Command Configuration

To control the drive with a Modbus Master, it is necessary to select Modbus as command channel active.

Goto to:

- **[1.3 CONFIGURATION]** (C D n F),
- **[FULL]** (F U L L)
- **[COMMAND]** (C t L -) menu

And then configure:

- **[Ref.1 channel]** (F r I) parameter to **[Modbus]** (M d b) value.

Communication Configuration

Select the Modbus address in the menu:

- **[1.3 CONFIGURATION]** (C D n F)
- **[FULL]** (F U L L)
- **[COMMUNICATION]** (C D n -) menu
- **[MODBUS NETWORK]** (M d I -)

And then configure:

- **[Modbus address]** (M d d) parameter to **[2]** (2) value.

The drive must be restarted in order to take into account the Modbus address.

Modbus Master Configuration

In this example, the Modbus Master configuration is done with Unity.

Serial Port Configuration

Configure the serial port as Master. The other default settings are compliant with the default settings of the ATV32.

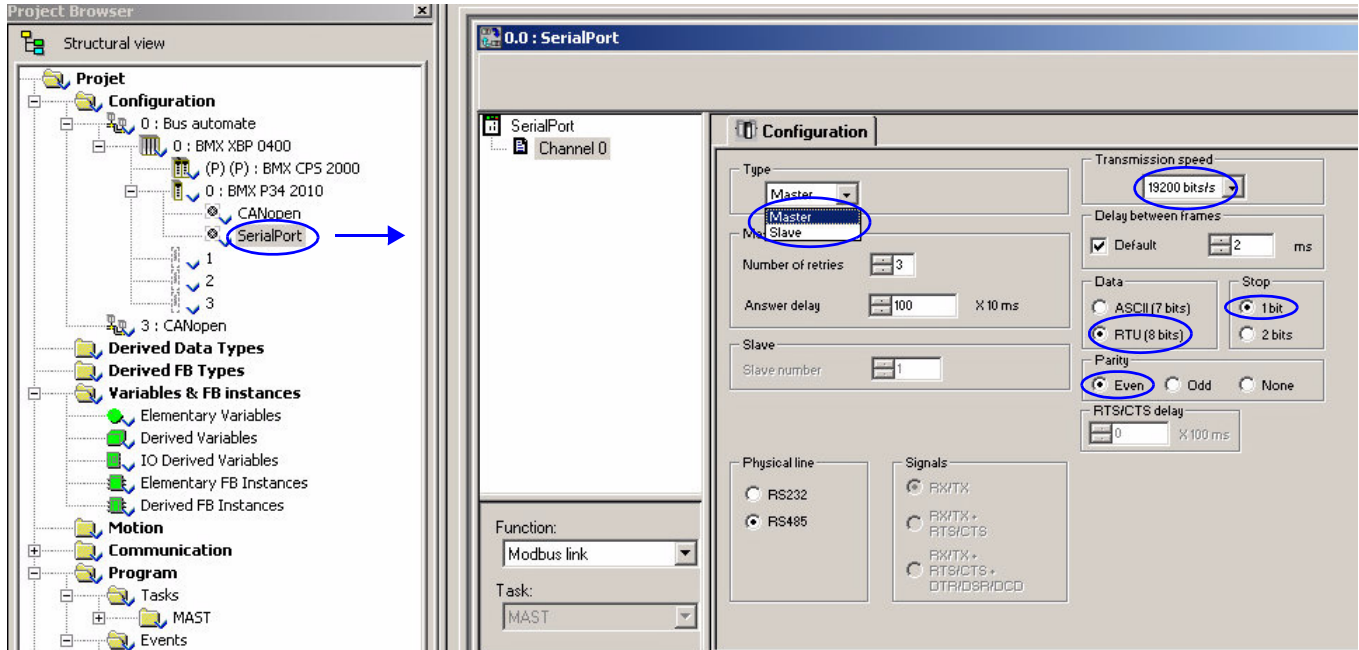

Data Structure Declaration

Create the following table (DevicePath). DevicePath describes the path to the device including its slave address.

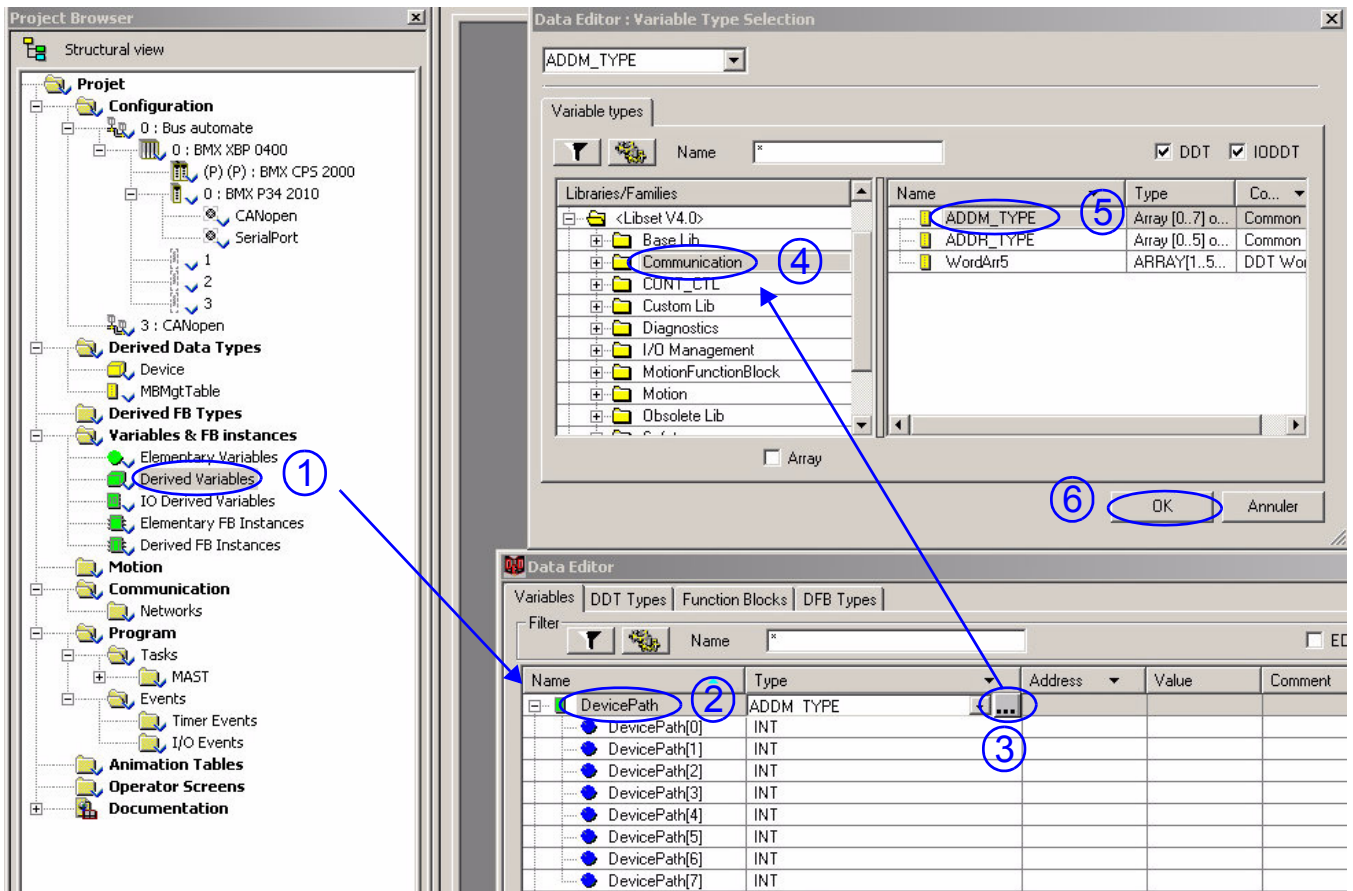

Then create the 4 others tables as arrays from 0 to 3 of integer.

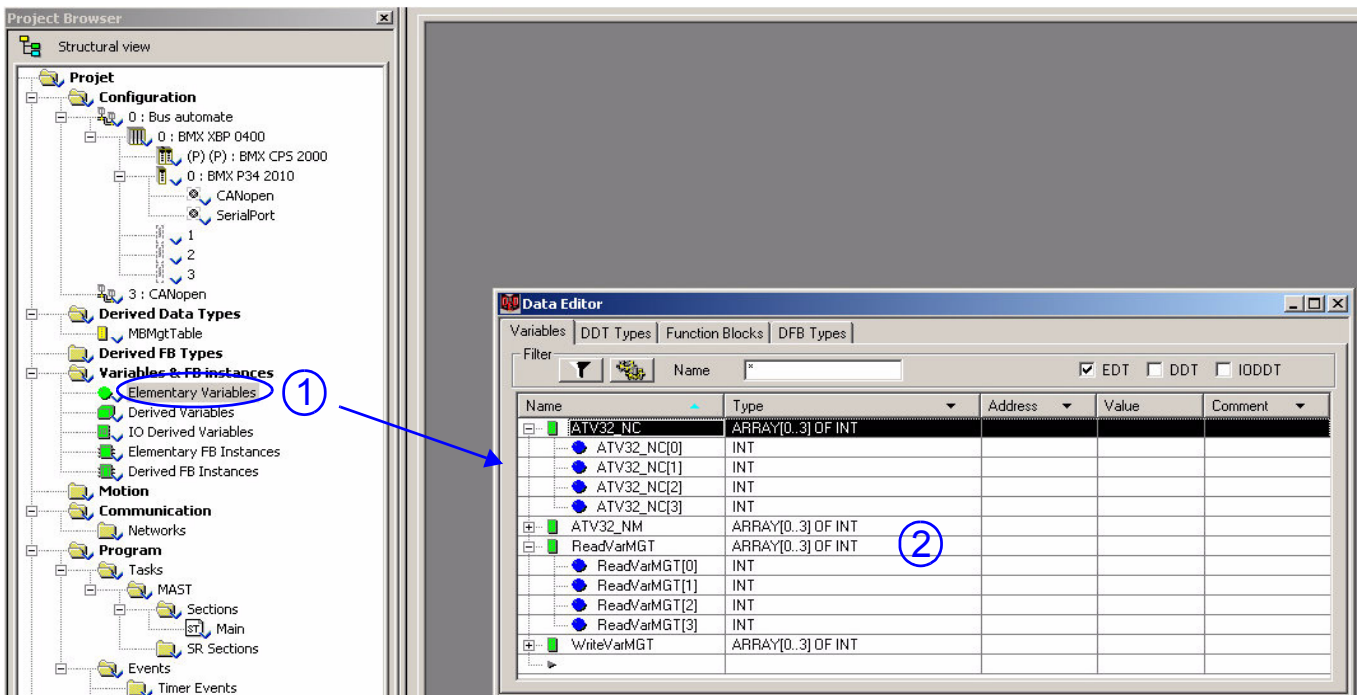

As all the tables declared are dynamic (no fixed address), it is necessary in the project setting to «Allows dynamic array» and to «Directly represented array variables». The parametrization must be done in the menu «Tool», «Project Settings», «Language extensions» window.

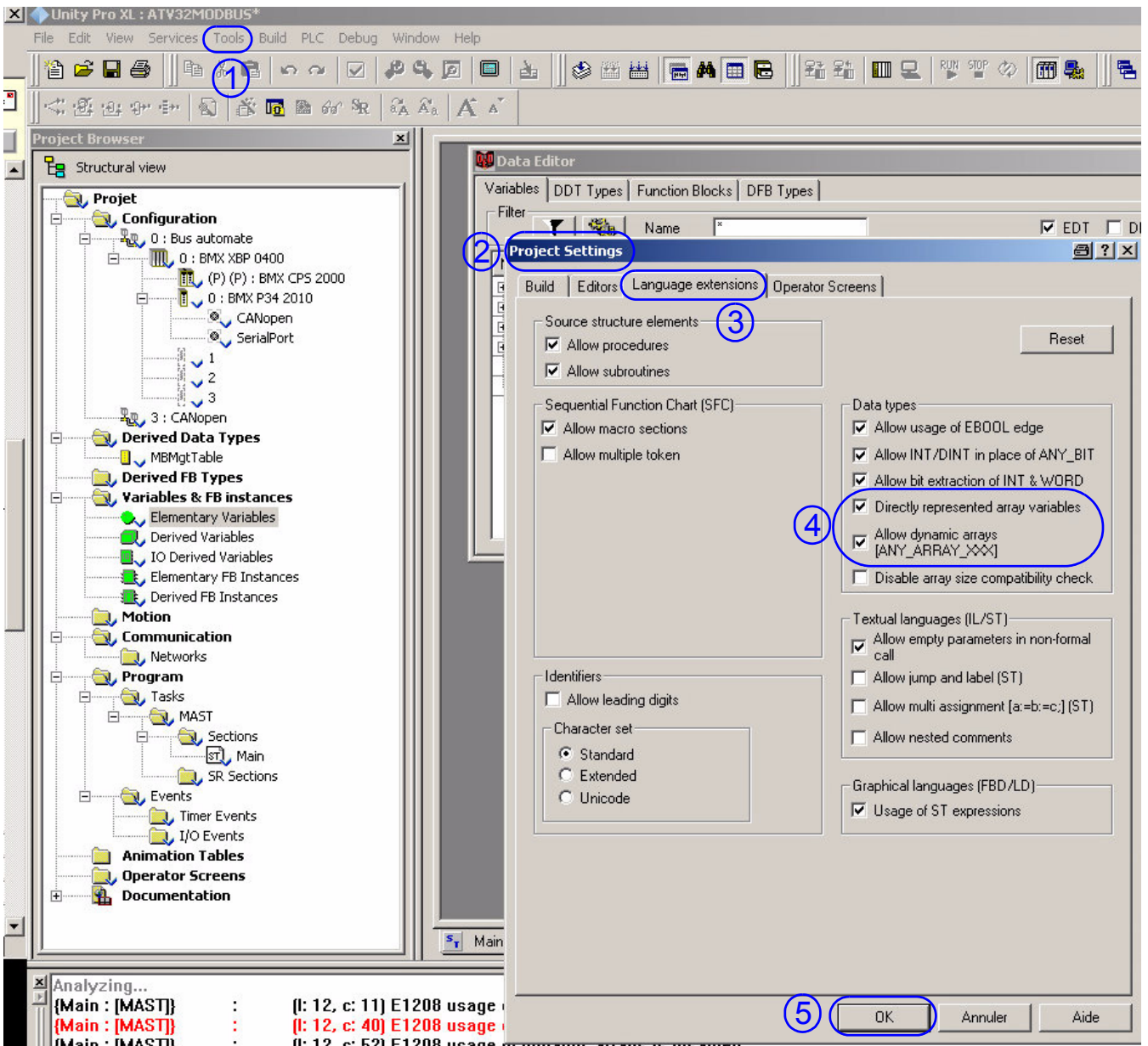

Program

Create a program in MAST section.

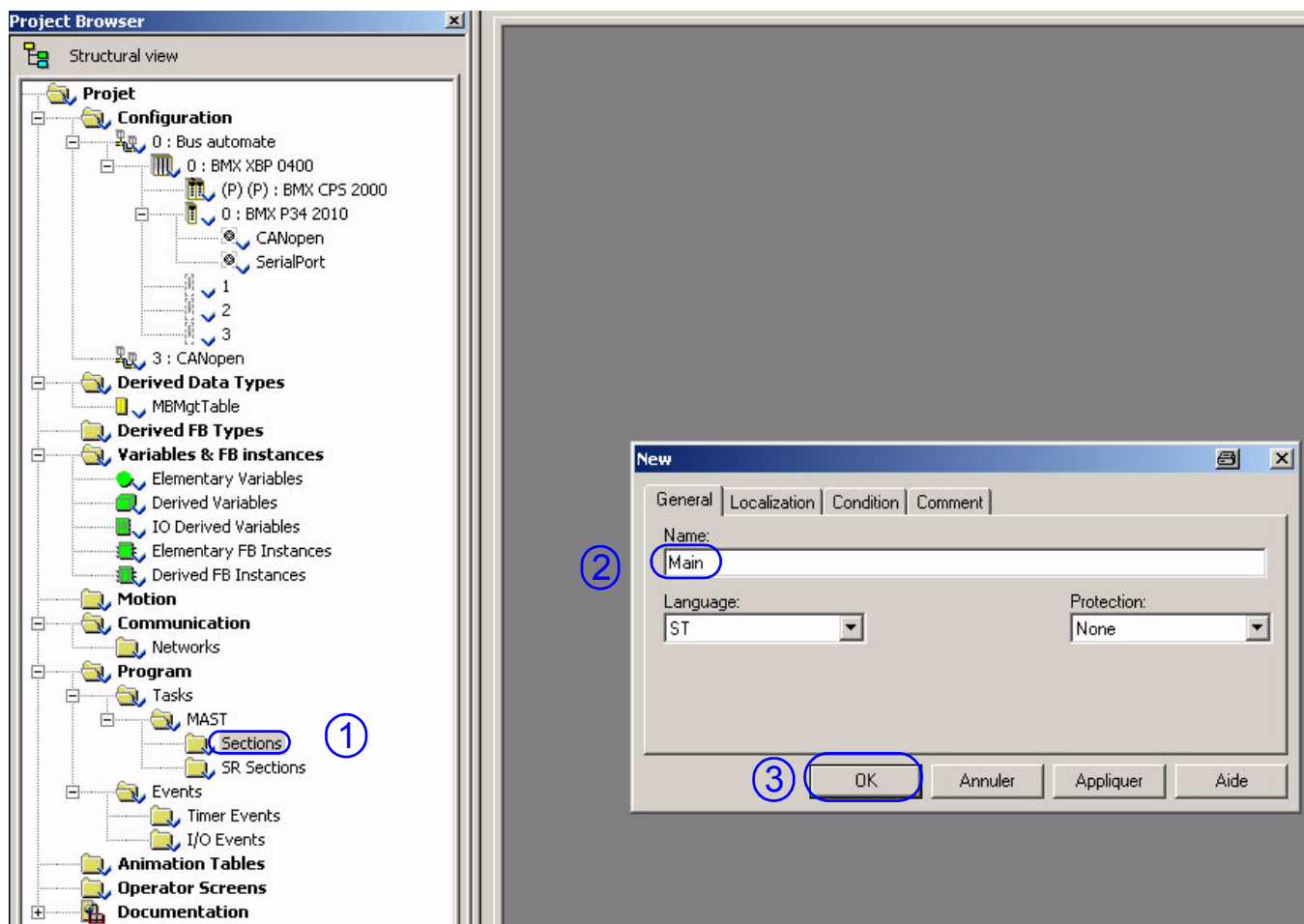

The communication is based on the READ_VAR, WRITE_VAR functions. During the first execution of the MAST task, you can initialize the data structure used by these two functions.

ReadVarMgt and WriteVarMgt are arrays used respectively by READ_VAR and WRITE_VAR. Only the 3rd element of these arrays is modifiable by the user to define the timeout duration of the requests.

In our example, the application manages 2 requests:

- A read request of 4 words starting at Modbus address 12741 (16#31C5). It is the address of the first word of the input scanner of the drive **[Com Scan In1 val.]** (n I). Modbus function #3. The information is sent from the PLC to the drive. The table ATV32_NM is used. The 2 first words are mapped by default.

Name	Address	Comment
ATV32_NM(0)	12741	default: ATV32 ETA (status word)
ATV32_NM(1)	12742	default: ATV32 RFRD (output speed)
ATV32_NM(2)	12743	-
ATV32_NM(3)	12744	-

- A write request of 4 words starting at Modbus address 12761 (16#31D9). It is the address of the first word of the input scanner of the drive **[Com Scan Out1 val.]** (n O I). Modbus function #16. The information is sent from the drive to the PLC. The table ATV32_NC is used. The 2 first words are mapped by default.

Name	Address	Comment
ATV32_NC(0)	12761	default: ATV32 CMD (command word)
ATV32_NC(1)	12762	default: ATV32 LFRD (speed referenced)
ATV32_NC(2)	12763	-
ATV32_NC(3)	12764	-

The screenshot displays the Unity Pro XL software interface for the project 'ATV32MODBUS'. The left pane shows the 'Project Browser' with a structural view of the project hierarchy. The right pane shows the 'Main : [MAST]' section of a ladder logic program.

Project Browser Structure:

- Project
 - Configuration
 - 0 : Bus automate
 - 0 : BMX XBP 0400
 - (P) : BMX CPS 2000
 - 0 : BMX P34 2010
 - CANopen
 - SerialPort
 - 1
 - 2
 - 3
 - 3 : CANopen
 - Derived Data Types
 - MBMgtTable
 - Derived FB Types
 - Variables & FB instances
 - Elementary Variables
 - Derived Variables
 - IO Derived Variables
 - Elementary FB Instances
 - Derived FB Instances
 - Motion
 - Communication
 - Networks
 - Program
 - Tasks
 - MAST
 - Sections
 - ST Main
 - SR Sections
 - Events
 - Timer Events
 - I/O Events
 - Animation Tables
 - Table
 - Operator Screens
 - Documentation

```

IF NOT init THEN
  (* ADDM has to be used to add the slave at address 2*)
  DevicePath := ADDM('0.0.0.2');

  (* Timeout duration *)
  ReadVarMGT[2] := 50;
  WriteVarMGT[2] := 50;

  (* the configuration has to be done only once *)
  init := TRUE;
END_IF;

IF NOT ReadVarMGT[0].0 THEN (* bit 0 is set when READ_VAR is busy *)
  (* read data is stored in ATV32_NM array *)
  READ_VAR(DevicePath, '%MW', 12741, 4, ReadVarMGT, ATV32_NM);
END_IF;

IF NOT WriteVarMGT[0].0 THEN (* bit 0 is set when WRITE_VAR is busy *)
  (* data to be written is stored in ATV32_NC array *)
  WRITE_VAR(DevicePath, '%MW', 12761, 4, ATV32_NC, WriteVarMGT);
END_IF;

```

Software Setup with SoMachine (M238)



7

What's in this Chapter?

This chapter contains the following topics:

Topic	Page
Introduction	50
Drive Configuration	51
Modbus Master Configuration	52

Introduction

Here is an example of an application that shows how to control an ATV32 with a M238 PLC equipped with a Modbus port. The operator can control the drive directly from SoMachine.

In the example, the communication scanner of the ATV32 is used. The PLC will send the command and the speed reference to the ATV32 and will read the status word and the actual speed of the drive.

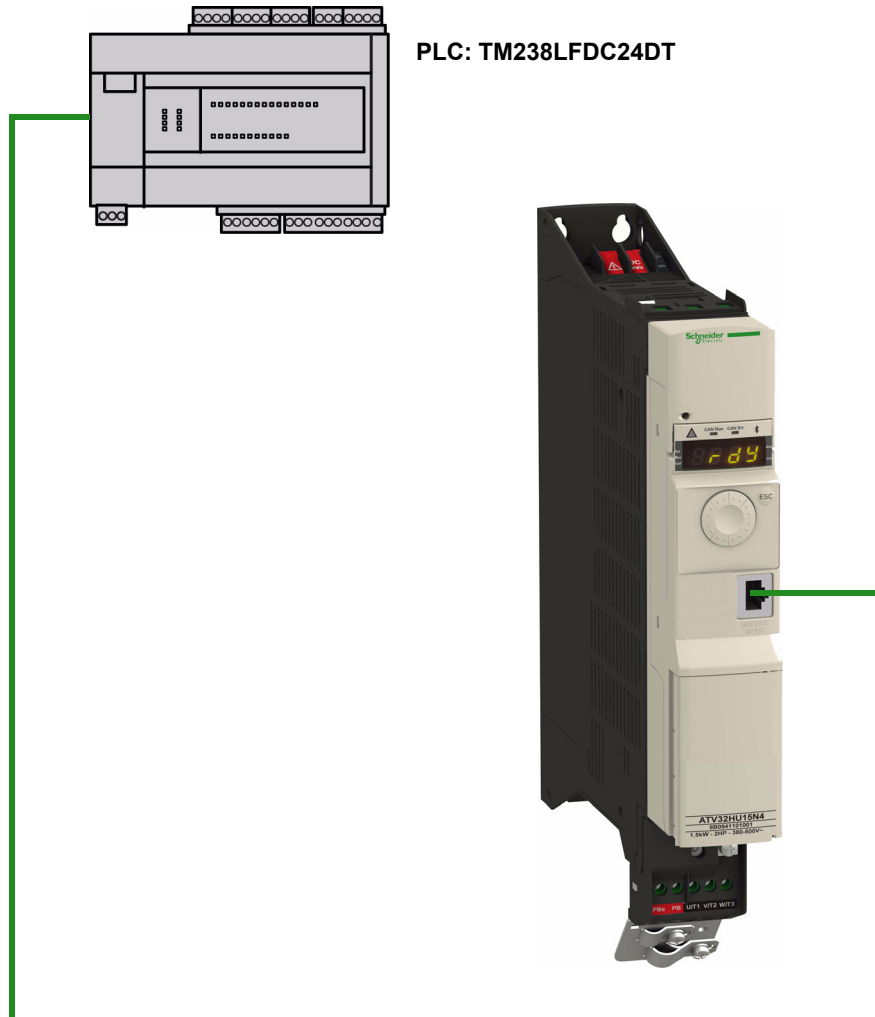

Drive Configuration

Factory Setting

Before configuring the drive, it's strongly advised to make a factory setting. Goto to:

- **[1.3 CONFIGURATION]** (C D n F) menu,
- **[FACTORY SETTINGS]** (F C S -) sub-menu.

Then configure the following parameters:

- **[PARAMETER GROUP LIST]** (F r Y) = **[All]** (A I I)
- **[Goto FACTORY SETTINGS]** (G F S) = enter

Command Configuration

To control the drive with a Modbus Master, it is necessary to select Modbus as command channel active.

Goto to:

- **[1.3 CONFIGURATION]** (C D n F),
- **[FULL]** (F U L L)
- **[COMMAND]** (C E L -) menu

And then configure:

- **[Ref. 1 channel]** (F r I) parameter to **[Modbus]** (M d b) value.

Communication Configuration

Select the Modbus address in the menu:

- **[1.3 CONFIGURATION]** (C D n F)
- **[FULL]** (F U L L)
- **[COMMUNICATION]** (C O M -) menu
- **[MODBUS NETWORK]** (M d I -)

And then configure:

- **[Modbus address]** (M d d) parameter to **[2]** (2) value.

The drive must be restarted in order to take into account the Modbus address.

Modbus Master Configuration

In this example, the Modbus master configuration is done with SoMachine.

Serial Port Configuration

Configure the serial port as Master.

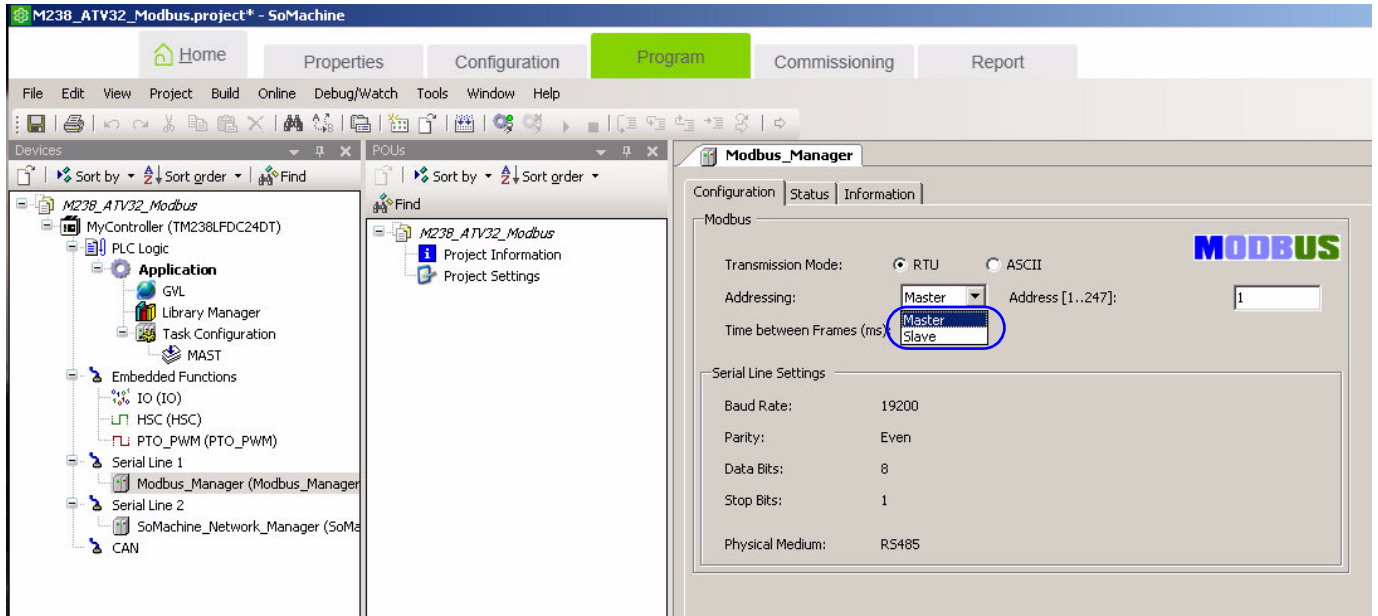

Add device Modbus IOScanner Schneider Electric

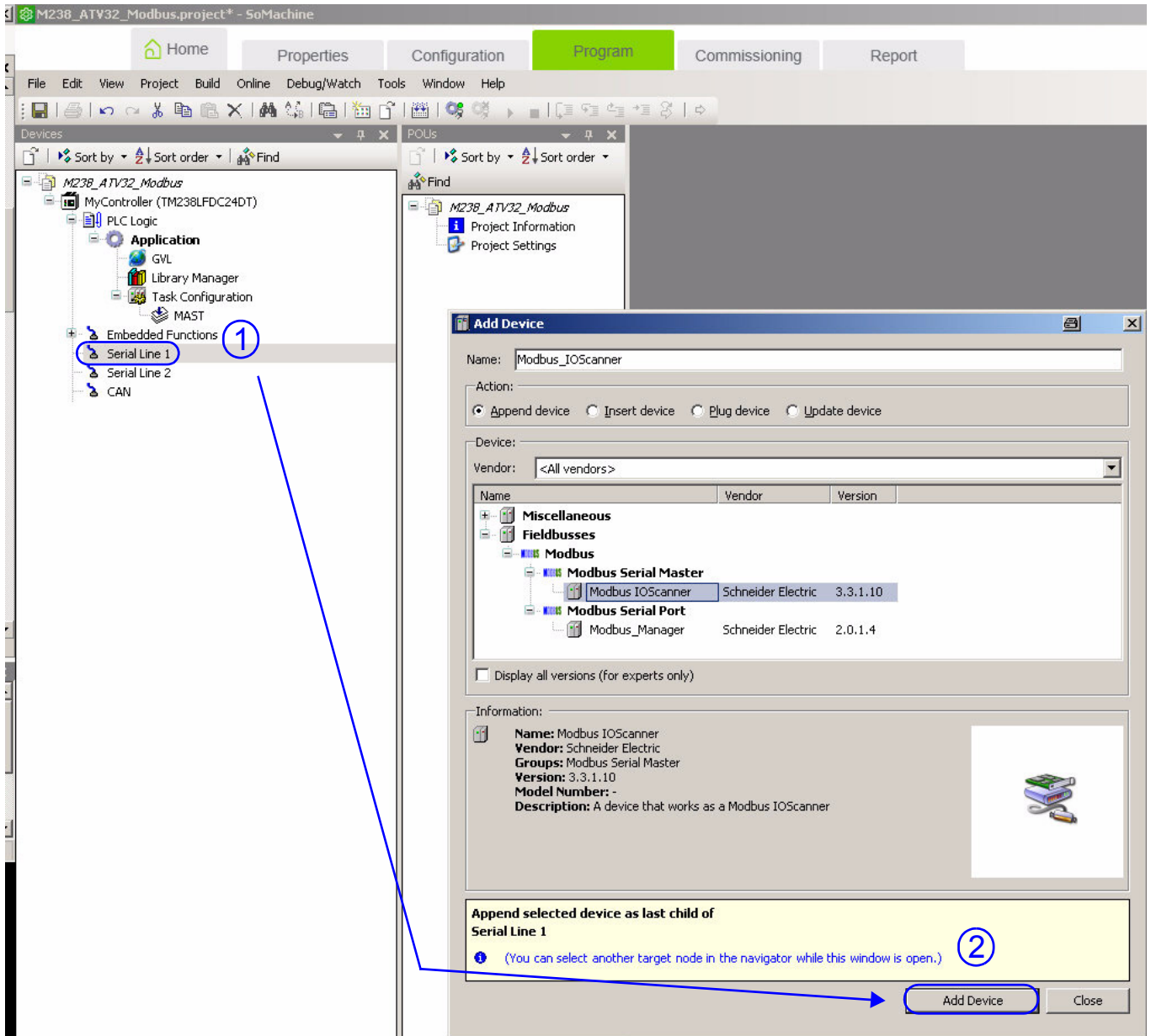

The other default settings are compliant with the default settings of the ATV32.

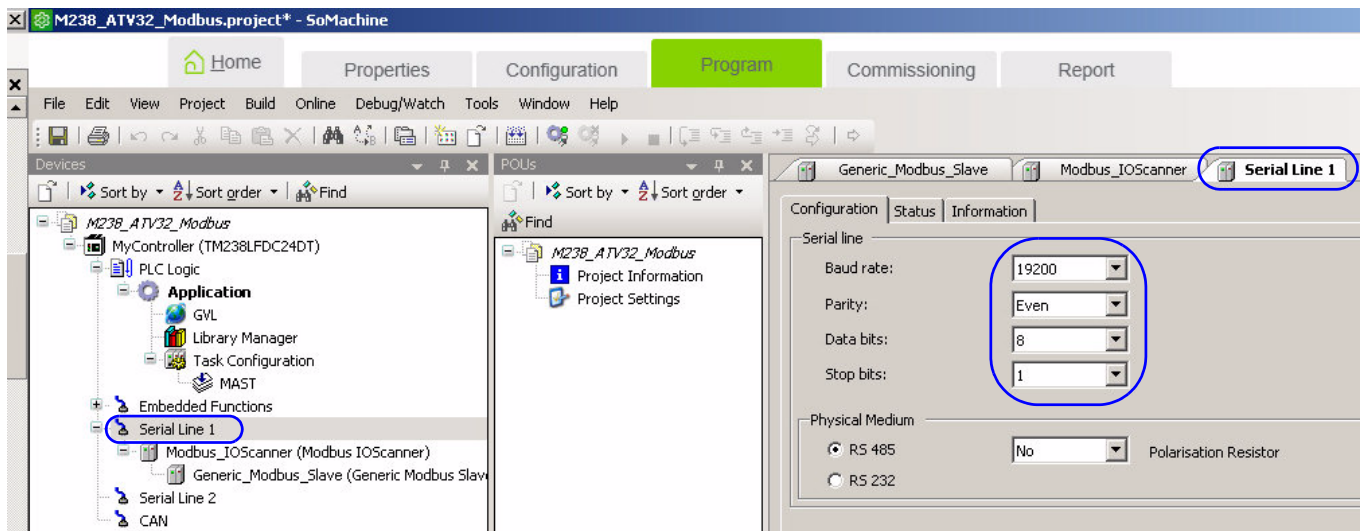

Configure the ATV32 slave address.

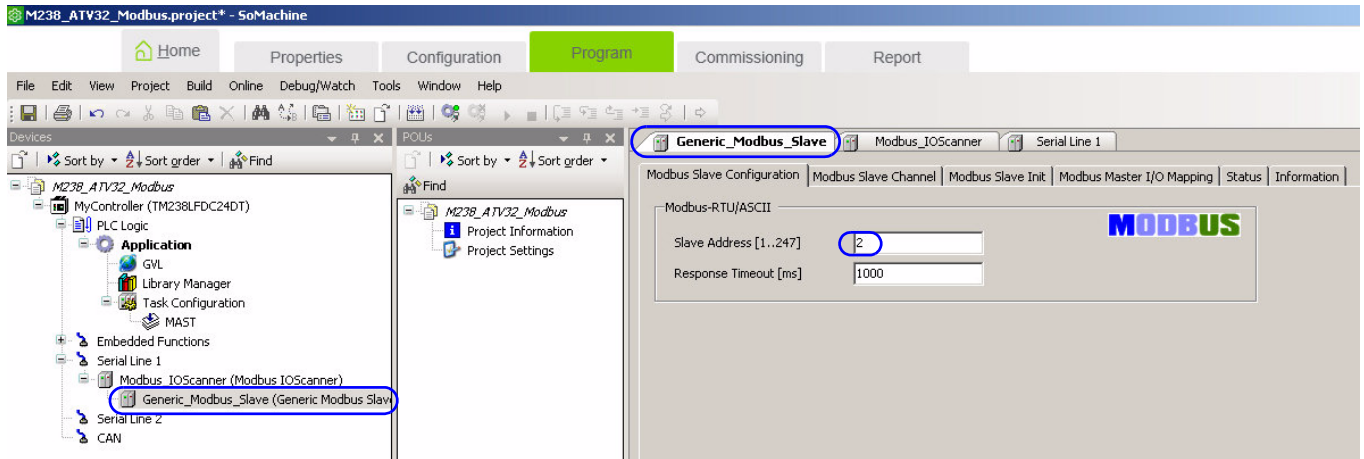

Check the transmission mode (RTU) and the timeout.

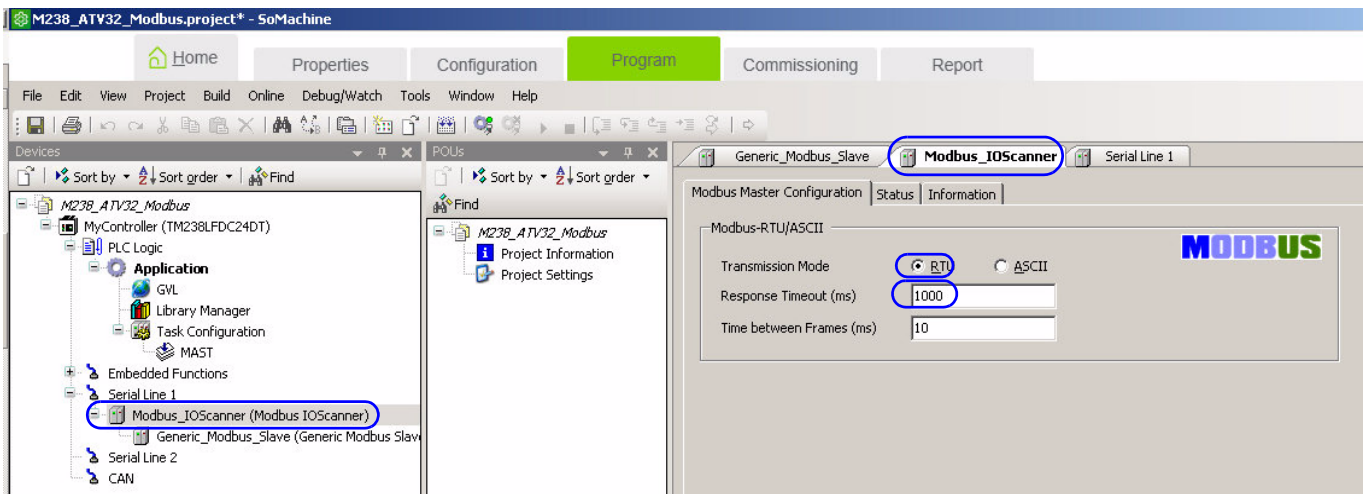

Read/Write Multiple Registers Function (#23)

The communication is based on the READ/WRITE Multiple registers function.

In our example, the application manages 1 function (#23) which includes 2 requests:

- A read request of 4 words starting at Modbus address 12741 (16#31C5). It is the address of the first word of the input scanner of the drive **[Com Scan In1 val.]** (n n I). The information is sent from the PLC to the drive. The 2 first words are mapped by default.

Name	Address	Comment
ATV32_NM(0)	12741	default: ATV32 ETA (status word)
ATV32_NM(1)	12742	default: ATV32 RFRD (output speed)
ATV32_NM(2)	12743	-
ATV32_NM(3)	12744	-

- A write request of 4 words starting at Modbus address 12761 (16#31D9). It is the address of the first word of the input scanner of the drive **[Com Scan Out1 val.]** (n E I). The information is sent from the drive to the PLC. The 2 first words are mapped by default.

Name	Address	Comment
ATV32_NC(0)	12761	default: ATV32 CMD (command word)
ATV32_NC(1)	12762	default: ATV32 LFRD (speed referenced)
ATV32_NC(2)	12763	-
ATV32_NC(3)	12764	-

- Select the Read/Write Multiple Registers function (1),
- Enter the address of the first read word and the length of the table (2),
- Enter the address of the first write word and the length of the table (3),
- Validate the function with «Enter» (4).

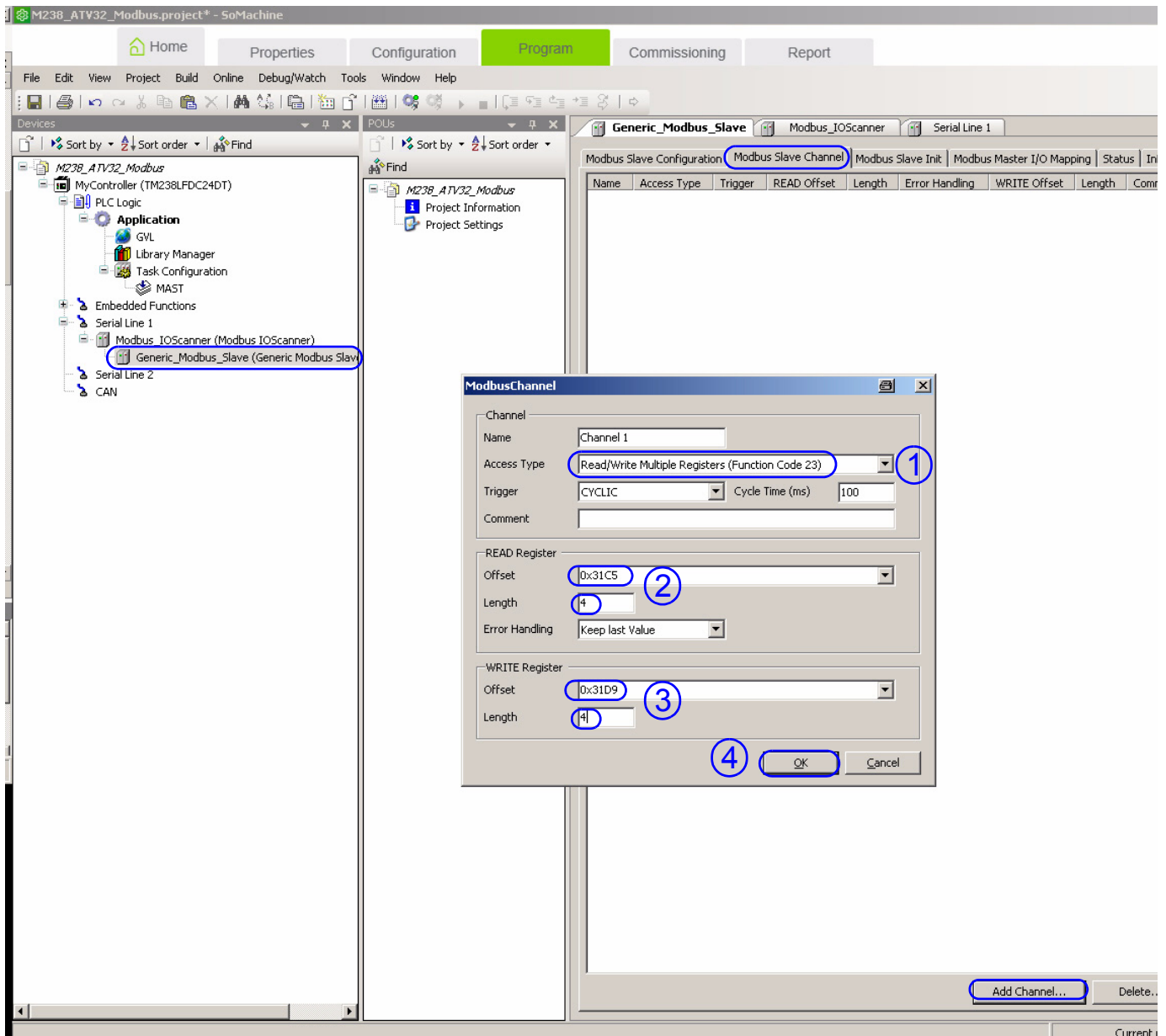

Use the «Modbus Master I/O Mapping» to exchange data with the drive.

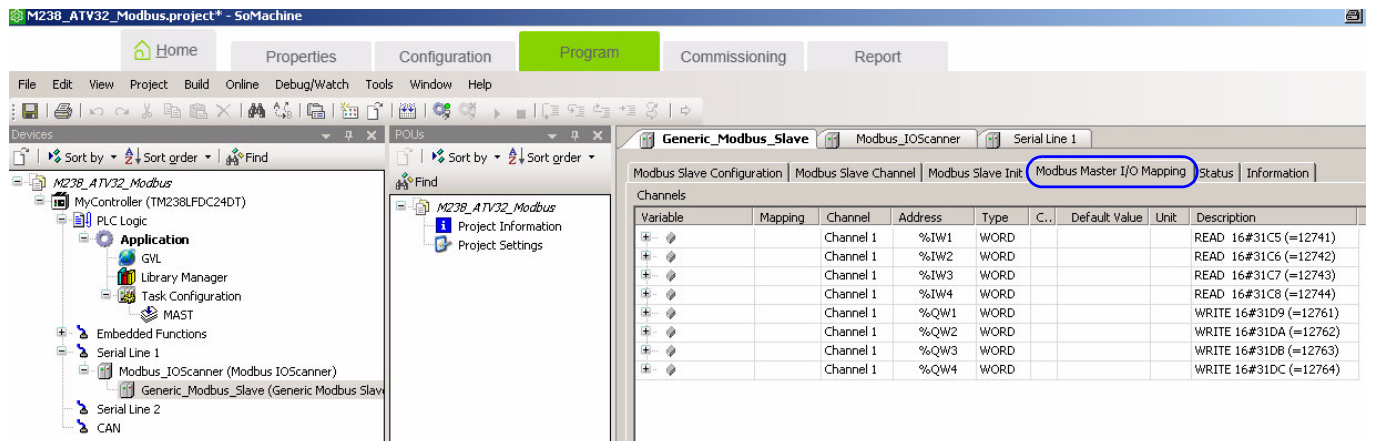

Modbus Functions



8

What's in this Chapter?

This chapter contains the following topics:

Topic	Page
Modbus Protocol	57
Supported Modbus Functions	58

Modbus Protocol

Introduction

The transmission mode used is RTU mode. The frame contains no message header byte, nor end of message bytes.

It is defined as follows:

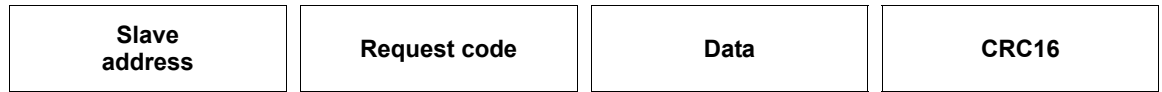

The data is transmitted in binary code.

CRC16: cyclical redundancy check.

The end of the frame is detected on a silence greater than or equal to 3 characters.

Principle

The Modbus protocol is a master-slave protocol.

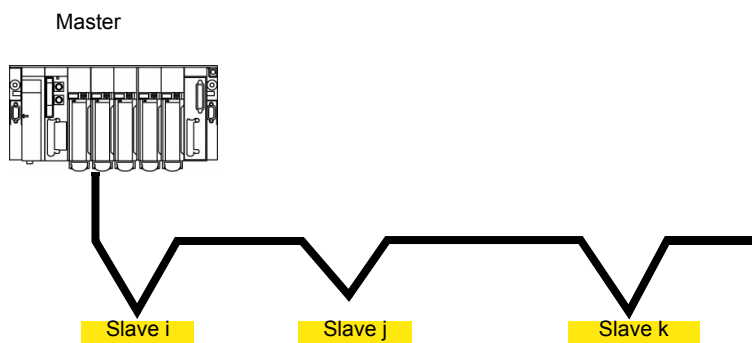

Only one device can transmit on the line at any time.

The master manages the exchanges and only it can take the initiative.

It interrogates each of the slaves in succession.

No slave can send a message unless it is invited to do so.

The master repeats the question when there is an incorrect exchange, and declares the interrogated slave absent if no response is received within a given time period.

If a slave does not understand a message, it sends an exception response to the master. The master may or may not repeat the request.

Direct slave-to-slave communications are not possible.

For slave-to-slave communication, the application software must therefore be designed to interrogate a slave and send back data received to the other slave.

Two types of dialogue are possible between master and slaves:

- the master sends a request to a slave and waits for its response
- the master sends a request to all slaves without waiting for a response (broadcasting principle)

Addresses

- The drive Modbus address can be configured from 1 to 247.
- Address 0 coded in a request sent by the master is reserved for broadcasting. ATV32 drives take account of the request, but do not respond to it.

Supported Modbus Functions

Introduction

The Altivar 32 supports the following Modbus functions:

Function name	Code	Description	Remarks
Read Holding Registers	03 16#03	Read N output words	Max PDU length: 63 words
Write One Output Word	06 16#06	Write one output word	-
Write Multiple Registers	16 16#10	Write N output word	Max PDU length: 61 words
Read/write Multiple Registers	23 16#17	Read/write multiple registers	Max PDU length: 20 words (W), 20 words (R)
(Sub-function) Read Device Identification	43/14 16#2B 16#0E	Encapsulated interface transport / Read device identification	-
Diagnostics	08	Diagnostics	-

Read Holding Registers

Request

Function code	1 Byte	16#03
Starting Address	2 Bytes	16#0000 to 16#FFFF
Quantity of Registers	2 Bytes	1 to 63 (16# 3F)

Response

Function code	1 Byte	16#03
Byte count	1 Byte	2 x N ⁽¹⁾
Register value	N ⁽¹⁾ x 2 Bytes	

(1) N: Quantity of Registers

Error

Error code	1 Byte	16#83
Exception code	1 Byte	01 or 02 or 03 or 04

Example

This function can be used to read all ATV32 words, both input words and output words.

Request

Slave no.	03	No. of first word	Number of words	CRC16
1 byte	1 byte	Hi Lo	Hi Lo	Lo Hi
		2 bytes	2 bytes	2 bytes

Hi = high order byte, Lo = low order byte.

Response

Slave no.	03	Number of bytes read	First word value	-----	Last word value	CRC16
1 byte	1 byte	1 byte	Hi Lo		Hi Lo	Lo Hi
		1 byte	2 bytes		2 bytes	2 bytes

Hi = high order byte, Lo = low order byte.

Example: read 4 words W3102 to W3105 (16#0C1E to 16#0C21) in slave 2, using function 3, where:

- SFr = Switching frequency = 4 kHz (W3102 = 16#0028)
- tFr = Maximum output frequency = 60 Hz (W3103 = 16#0258)
- HSP = High speed = 50 Hz (W3104 = 16#01F4)
- LSP = Low speed = 0 Hz (W3105 = 16#0000)

Request:

02	03	0C1E	0004	276C
----	----	------	------	------

Response:

02	03	08	0028	0258	01F4	0000	52B0
	Value of:		W3102	W3103	W3104	W3105	
	Parameters:		SFr	tFr	HSP	LSP	

Write One Output Word

Request

Function code	1 Byte	16#06
Register Address	2 Bytes	16#0000 to 16#FFFF
Register value	2 Bytes	16#0000 to 16#FFFF

Response

Function code	1 Byte	16#06
Register Address	2 Bytes	16#0000 to 16#FFFF
Register value	2 Bytes	16#0000 to 16#FFFF

Error

Error code	1 Byte	16#86
Exception code	1 Byte	01 or 02 or 03 or 04

Example

Request and response (the frame format is identical)

Slave no.	06	Word number		Value of word		CRC16	
		Hi	Lo	Hi	Lo	Lo	Hi
1 byte	1 byte	2 bytes		2 bytes		2 bytes	

Example: write value 16#000D in word W9001 (16#2329) in slave 2 (ACC = 1.3 s).

Request and response	02	06	2329	000D	9270
----------------------	----	----	------	------	------

Write Multiple Register

Request

Slave no.	10	No. of first word		Number of words		Number of bytes	Value of first word		--	CRC16	
		Hi	Lo	Hi	Lo		Hi	Lo		Lo	Hi
1 byte	1 byte	2 bytes		2 bytes		1 byte	2 bytes			2 bytes	

Response

Slave no.	10	No. of first word		Number of words		CRC16	
		Hi	Lo	Hi	Lo	Lo	Hi
1 byte	1 byte	2 bytes		2 bytes		2 bytes	

Example: Write values 20 and 30 to words W9001 and W9002 on slave 2 (acceleration time = 2 s and deceleration time = 3 s)

Request

Slave no.	Request code	No. of first word		Number of words		Number of bytes	Value of first word		Value of second word		CRC16	
		Hi	Lo	Hi	Lo		Hi	Lo	Hi	Lo	Lo	Hi
02	10	23	29	00	02	04	00	14	00	1E	73	A4

Response

Slave no.	Response code	No. of first word		Number of words		CRC16	
		Hi	Lo	Hi	Lo	Lo	Hi
02	10	23	29	00	02	9B	B7

(hexadecimal values)

Read/write Multiple Registers

Description	Length in byte	Value	Comment
Function code	1	16#17	-
Read starting address	2	16#XXXX	Always Modbus address
Quantity	2	16#03	Contain number of holding registers to be read
Write starting address	2	16#XXXX	Always Modbus address
Quantity	2	16#03	Contain number of holding registers to be written
Write Byte count	1	16#06	The byte count specifies the number of bytes to follow in the field Write Register Value
Write Registers Value	6	16#XX XXXX XXXX XX	Value to be written respectively in NCA1 to NCA3, so the configured example: CMD, LFRD, CMI

Example

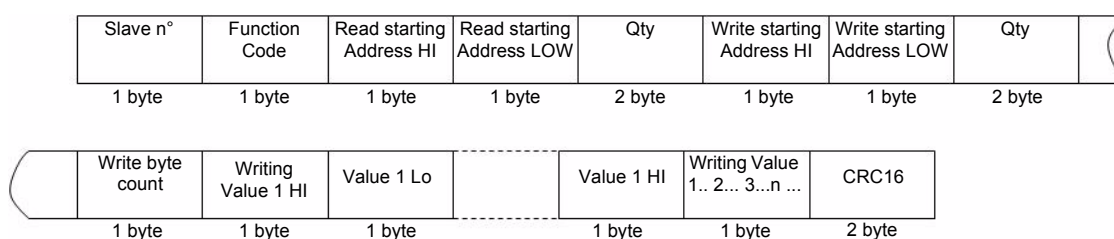

Read Device Identification

ID	Name / Description	Type
16#00	VendorName	ASCII String
16#01	ProductCode	ASCII String
16#02	MajorMinorRevision	ASCII String
16#04	ProductName	ASCII String

Example

Default values to be detailed

Request

Slave no.	2B	Type of MEI 0E	ReadDeviceld 01	Object Id 00	CRC16 Lo Hi	
1 byte	1 byte	1 byte	1 byte	1 byte	2 bytes	

Response

Slave no.	2B	Type of MEI 0E	ReadDeviceld 01	Degree of conformity 02	-----
1 byte	1 byte	1 byte	1 byte	1 byte	

-----	Number of additional frames 00	Next object Id 00	Number of objects 03	-----
	1 byte	1 byte	1 byte	

-----	Id of object no. 1 00	Length of object no. 1 12	Value of object no. 1 "Schneider Electric"	-----
	1 byte	1 byte	18 bytes	

-----	Id of object no. 2 01	Length of object no. 2 0B	Value of object no. 2 "ATV32HU75M3"	-----
	1 byte	1 byte	11 bytes	

-----	Id of object no. 3 02	Length of object no. 3 04	Value of object no. 3 "0201"	-----
	1 byte	1 byte	4 bytes	

-----	CRC16	
	Lo	Hi
	1 byte	1 byte

The total response size equals 49 bytes

The three objects contained in the response correspond to the following objects:

- Object no. 1: Manufacturer name (always "Schneider Electric", ie. 18 bytes).
- Object no. 2: Device reference (ASCII string; *for example*: "ATV32HU75M3", ie. 11 bytes).
- Object no. 3: Device version, in "MMmm" format where "MM" represents the determinant and "mm" the subdeterminant (4-bytes ASCII string; *for example*: "0201" for version 2.1).

NOTE: The response to function 43 may be negative; in this case, the response located at the top of the next page is sent by the Altivar 32 rather than the response described above.

Diagnostics

Subcode 16#00: Echo

This function asks the slave being interrogated to echo (return) the message sent by the master in its entirety.

Subcode 16#0A: Counter reset

This function resets all the counters responsible for monitoring a slave's exchanges.

Subcode 16#0C: Read message counter responsible for counting messages received with checksum errors

Subcode 16#0E: Read message counter responsible for counting messages addressed to slave

Read a word indicating the total number of messages addressed to the slave, regardless of type (excluding broadcast messages).

Request and response

Slave no.	08	Subcode		Data		CRC16	
		Hi	Lo	Hi	Lo	Lo	Hi
1 byte	1 byte	2 bytes		N bytes		2 bytes	

Subcode	Request data	Response data	Function executed
00	XX YY	XX YY	Echo
0A	00 00	00 00	Counter reset
0C	00 00	XX YY (= counter value)	Read message counter responsible for counting messages received with checksum errors
0E	00 00	XX YY (= counter value)	Read message counter responsible for counting messages addressed to slave

Example: Values 16#31 and 16#32 echoed by slave 4

Request and response (if function successful)

Slave no.	Request code or Response code	Subcode		Value of 1 st byte	Value of 2 nd byte	CRC16	
		Hi	Lo			Lo	Hi
04	08	00	00	31	32	74	1B

(hexadecimal values)

